

Series 50

Detectors-Transmitters for Flammable, Toxic Gases and Oxygen

- Intrinsically Safe (IS) and XP approved
- Pre-calibrated sensor unit
- Resistant to corrosive agents
- IP 66



OLC(T) 50



OLC(T) 50D

Introducing the OLC(T) 50, a new generation of high quality gas detectors designed for manufacturers, refineries and other industries to accommodate your gas detection requirements at a great price.

OLC(T) 50 Detector

The enclosure, which is made of alloy AS7 606 is coated with polyester epoxy paint (stainless-steel is also an option), and is rugged and resistant to corrosive agents. The OLC(T) 50 detectors are practical and easy to use. The combustible gas sensors are insensitive to poisons, offer quick response times and provide accurate gas measurement.

OLC(T) 50D Detector

Based on the OLC(T) 50 detector-transmitter, the OLC(T) 50D allows the detector unit to be used in remote mode.

The detector is equipped with a 15 meter long cable (standard) and a packing gland for direct connection for detection in difficult locations.

New Generation: New Advantages

The detector units, which are made of 316L stainless steel, are durable and resistant to harsh environmental elements. Certified IP 66, OLC 50 and OLCT 50 Series are tightly sealed to avoid contamination from dust and liquid splashes. The pre-calibrated sensors of the OLCT 50 and OLCT 50D can be disconnected by simply turning the head of the unit. The "smart" sensors can be calibrated outside hazardous areas on a bench.

**INDUSTRIAL
SCIENTIFIC**

www.indsci.com

Series 50

SENSOR SPE

Gases	Type of sensor	Range (ppm)	Operating temperature*	Relative humidity uncondensed
O ₂	electrochemical	30,00%	-20°C to +50°C	10% to 95% RH
CO	electrochemical	100, 300 and 1000	-20°C to +50°C	10% to 95% RH
H ₂ S	electrochemical	30, 100 and 1000	-20°C to +50°C	10% to 95% RH
NO	electrochemical	100, 300 and 1000	-20°C to +50°C	10% to 95% RH
NO ₂	electrochemical	10 and 30,0	-20°C to +50°C	10% to 95% RH
SO ₂	electrochemical	10,0 30,0 and 100	-10°C to +50°C	10% to 95% RH
Cl ₂	electrochemical	10	-20°C to +50°C	10% to 95% RH
H ₂	electrochemical	2000	-20°C to +50°C	10% to 95% RH
HCl	electrochemical	30,0 and 100	-20°C to +40°C	10% to 95% RH
HCN	electrochemical	10,0 and 30,0	-20°C to +40°C	10% to 95% RH
NH ₃	electrochemical	100	-20°C to +40°C	10% to 95% RH
		1000	-20°C to +40°C	10% to 95% RH
O ₃	electrochemical	1	-10°C to +40°C	10% to 95% RH
PH ₃	electrochemical	1	-20°C to +40°C	10% to 95% RH
ClO ₂	electrochemical	3	-20°C to +50°C	10% to 95% RH
SiH ₄	electrochemical	50	-20°C to +40°C	10% to 95% RH
AsH ₃	electrochemical	1	-10°C to +40°C	20% to 95% RH
CH ₄	catharometer	0-100% vol	-20°C to +50°C	10% to 95% RH
H ₂	catharometer	0-100% vol	-20°C to +50°C	10% to 95% RH
NH ₃	catalytic	0-5000	-20°C to +50°C	10% to 95% RH
Flammable gas	catalytic	0-100% LEL	-20°C to +70°C	10% to 95% RH
			-20°C to 200°C	10% to 95% RH

* Temperature at 20°C and at Atmospheric Pressure

OLCT 50 Transmitter

The housing of the new generation OLCT 50 transmitters is especially resistant to external contaminants. These transmitters are practical and easy to use. Their pre-calibrated sensors carry "XP" or "IS" approval (depending on which gases they detect).

OLCT 50D Transmitter

Based on the OLCT 50, the OLCT 50D allows the sensor to be used in remote mode. The detector is equipped with a 15 meter long cable (standard) and a packing gland for direct connection to a data logger to allow for detection in difficult locations.

Drawing of connections per zone

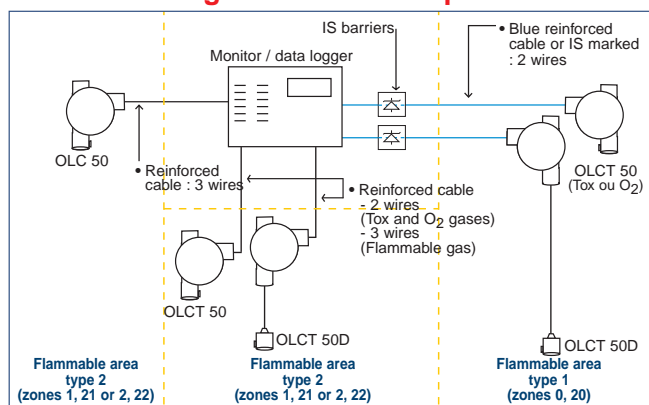

PECIFICATIONS

Pressure	Accuracy at full scale (at atmospheric pressure)	Life span (in month)	T (50)	IP	IS	AD
Atm +/- 10%	from 5 to 30% = 0,4%vol	28	6	66	YES	YES
Atm +/- 10%	+/- 2 ppm (range 0-100)	48	10	66	YES	YES
Atm +/- 10%	+/- 1,5 ppm (between 0-30 ppm)	48	15	66	YES	YES
Atm +/- 10%	+/- 2 ppm (range 0-100)	36	15	66	YES	YES
Atm +/- 10%	+/- 0,8 ppm	26	20	66	YES	NO
Atm +/- 10%	+/- 0,7 ppm range 0-10	36	15	66	YES	NO
Atm +/- 10%	+/- 0,5 ppm	26	50	66	YES	NO
Atm +/- 10%	+/-5 ppm range 0-100	26	50	66	YES	YES
Atm +/- 10%	+/- 0,5 ppm range 0-10	26	50	66	YES	NO
Atm +/- 10%	+/- 0,3 ppm range 0-10	26	40	66	YES	NO
Atm +/- 10%	+/- 5 ppm	26	50	66	YES	YES
Atm +/- 10%	+/- 10 ppm range 0-1000	26	50	66	YES	YES
Atm +/- 10%	+/-0,05 ppm	20	50	66	YES	NO
Atm +/- 10%	+/- 0,05 ppm	20	40	66	YES	NO
Atm +/- 10%	+/- 0,3 ppm	26	50	66	YES	NO
Atm +/- 10%	+/- 1 ppm	20	40	66	YES	NO
Atm +/- 10%	+/- 0,05 ppm	26	40	66	YES	NO
Atm +/- 10%	1% vol	60	5	66		
Atm +/- 10%	1% vol	60	5	66	YES	YES
Atm +/- 10%	100 ppm	36	8	66	YES	YES
Atm +/- 10%	1% LEL between 0- 60% LEL	60	5	66		
Atm +/- 10%	1% LEL between 0- 60% LEL	60	5	66		

1. Tool kit

2. Calibration cup:

- standard model: LEL, O₂, CO, H₂S, NO, H₂
- model for special gases: NO₂, SO₂, Cl₂, HCl, HCN, NH₃, O₃, ClO₂, PH₃, AsH₃, SiH₄

3. Bypass adapter for combustible gases, CO, H₂S, O₂

4. Splash guard

5. Remote gas introduction device

6. PTFE protective filter/ Activated carbon filter

7. Mounting bracket

8. Gas collectors

9. Pitot tube

10. Remote mounting bracket



Series 50

SPECIFICATIONS

Detectors	OLCT 50		OLCT 50D		OLC 50	OLC 50D
Type	Flameproof transmitter	IS transmitter	Flameproof transmitter	IS remote transmitter	Flameproof detector	Remote Flameproof detector
Gas detection principle	Catalytic/electrochemical	Electrochemical	Catalytic/electrochemical	Electrochemical	Catalytic	Catalytic
Detected gases	Flammable and toxic gases, oxygen	Toxic and oxygen	Flammable and toxic gases, oxygen	Toxic and oxygen	Flammable gases	Flammable gases
Measuring ranges	See chart inside					
Enclosure	Alloy AS7 606 - epoxy polyester paint					
Sensor						
Sensor housing	Stainless steel type 316 L					
Pre-calibrated sensor	yes	yes	yes	yes	no	no
Power supply at the detector	15 to 30 VDC (catalytic) 10 to 30 VDC (chemical)	10 to 26 VDC	15 to 30 VDC (catalytic)	10 to 26 VDC 10 to 30 VDC (chemical)	2,7 VDC max	2,7 VDC max
Maximum power consumption	100 mA (catalytic) 25 mA (chemical)	25 mA	100 mA (catalytic)	25 mA 25 mA (chemical)	350 mA max	350 mA max
Output signal	4-20 mA		4-20 mA		Wheatstone bridge	Wheatstone bridge
Load impedance	250 Ω (catalytic) Depending on power supply (chemical)	47 Ω max	250 Ω (catalytic)	47 Ω max Depending on power supply (chemical)	Not applicable	Not applicable
Wiring	3 reinforced wires (catalytic) 2 reinforced wires (chemical)	2 reinforced wires	3 reinforced wires	2 reinforced wires (catalytic) 2 reinforced wires (chemical)	3 reinforced wires	3 reinforced wires
Loop impedance	32 Ω (catalytic) (1 km in 1,5 mm ²) 128 Ω (chemical) (4 km in 1,5 mm ²)	32 Ω (catalytic) (1 km in 1,5 mm ²)	32 Ω (catalytic) (1 km in 1,5 mm ²) 128 Ω (chemical) (4 km in 1,5 mm ²)	32 Ω (catalytic) (1 km in 1,5 mm ²)	32 Ω (catalytic) (1 km in 1,5 mm ²)	32 Ω (catalytic) (1 km in 1,5 mm ²)
Wiring connection	Gland - cable 2 to 12 mm (standard)					
Fastening	2 x 7 mm holes					
Ingress protection	IP 66					
Certification	⊕ EEx d IIC T6 ATEX II 2 GD INERIS 01ATEX0027X	⊕ EEx ia IIC T4 ATEX II 1 GD INERIS 01ATEX0027X	⊕ EEx d IIC T6 ATEX II 2 GD INERIS 01ATEX0027X	⊕ EEx ia IIC T4 ATEX II 1 GD INERIS 01ATEX0027X	⊕ EEx d IIC T6 ATEX II 2 GD INERIS 01ATEX0027X	⊕ EEx d IIC T6 ATEX II 2 GD INERIS 01ATEX0027X
CEM mark	EN 50270	EN 50270	EN 50270	EN 50270	EN 50270	EN 50270
Weight	1,9 kg		1,1 kg (casing)		1,1 kg	1,1 kg
Dimensions	L 154 x I 233 x H 121	L 154 x I 233 x H 121	L 154 x I 170 x H 121	L 154 x I 170 x H 121	L 154 x I 160 x H 121	L 154 x I 170 x H 121
Operating temperature	-25°C to +60°C		-25°C to +60°C		-25°C to +70°C -25°C to +200°C in HT version	

INDUSTRIAL SCIENTIFIC CORPORATION

CORPORATE HEADQUARTERS

1001 Oakdale Road • Oakdale, PA • 15071-1500 • USA

www.indsci.com



AMERICAS

Tel.: +1-412-788-4353

Fax: +1-412-788-8353

info@indsci.com

ASIA PACIFIC

Tel.: 86-10-8497-3970

Fax: 86-10-8497-3971

sales@isc-cn.com

EUROPE

Tel.: 33-3-21-60-80-80

Fax: 33-3-21-60-80-00

info@groupoldham.com

AUSTRALIA / NZ

Tel.: +61-2-8870-3400

GERMANY

Tel.: +49-231 / 9241-0

MIDDLE EAST

Tel.: +971-50-455-8518

SINGAPORE

Tel.: +65-6561-7377

UNITED KINGDOM

Tel.: +44-0-1782-562002

CZECH REPUBLIC

Tel.: +420-234-622-222/3

ITALY

Tel.: +39-011-3801371

NETHERLANDS

Tel.: +31-76-5427-609

SWITZERLAND

Tel.: +41-26-652-51-18