



INSTRUMENTS

M2 Rig Monitor Operator's Manual

Part Number: 71-0234RK

Revision: A

Released: 12/27/13

**RKI Instruments, Inc.
www.rkiinstruments.com**

WARNING

Read and understand this instruction manual before operating instrument. Improper use of the gas monitor could result in bodily harm or death.

Periodic calibration and maintenance of the gas monitor is essential for proper operation and correct readings. Please calibrate and maintain this instrument regularly! Frequency of calibration depends upon the type of use you have and the sensor types. Typical calibration frequencies for most applications are between 3 and 6 months, but can be required more often or less often based on your usage.

Product Warranty

RKI Instruments, Inc. warrants gas alarm equipment sold by us to be free from defects in materials, workmanship, and performance for a period of one year from date of shipment from RKI Instruments, Inc. Any parts found defective within that period will be repaired or replaced, at our option, free of charge. This warranty does not apply to those items which by their nature are subject to deterioration or consumption in normal service, and which must be cleaned, repaired, or replaced on a routine basis. Examples of such items are:

- a) Absorbent cartridges
- b) Pump diaphragms and valves
- c) Fuses
- d) Batteries
- e) Filter elements

Warranty is voided by abuse including mechanical damage, alteration, rough handling, or repair procedures not in accordance with the operator's manual. This warranty indicates the full extent of our liability, and we are not responsible for removal or replacement costs, local repair costs, transportation costs, or contingent expenses incurred without our prior approval.

THIS WARRANTY IS EXPRESSLY IN LIEU OF ANY AND ALL OTHER WARRANTIES AND REPRESENTATIONS, EXPRESSED OR IMPLIED, AND ALL OTHER OBLIGATIONS OR LIABILITIES ON THE PART OF RKI INSTRUMENTS, INC. INCLUDING BUT NOT LIMITED TO, THE WARRANTY OF MERCHANTABILITY OR FITNESS FOR A PARTICULAR PURPOSE. IN NO EVENT SHALL RKI INSTRUMENTS, INC. BE LIABLE FOR INDIRECT, INCIDENTAL, OR CONSEQUENTIAL LOSS OR DAMAGE OF ANY KIND CONNECTED WITH THE USE OF ITS PRODUCTS OR FAILURE OF ITS PRODUCTS TO FUNCTION OR OPERATE PROPERLY.

This warranty covers instruments and parts sold to users by authorized distributors, dealers, and representatives as appointed by RKI Instruments, Inc.

We do not assume indemnification for any accident or damage caused by the operation of this gas monitor, and our warranty is limited to the replacement of parts or our complete goods.

Table of Contents

Chapter 1: Introduction	1
Overview	1
About the M2 Rig Monitor	1
About this Manual.....	1
Specifications	2
Chapter 2: Description	3
Overview	3
External Description	3
Internal Description	6
Chapter 3: Installation & Startup	10
Overview	10
Mounting the M2 Rig Monitor	10
Wiring the M2 Rig Monitor	12
Start Up	15
Chapter 4: Operation	17
Overview	17
Normal Operation	17
Information Screen.....	17
4 - 20 mA Signal Output Operation	18
Alarm Indications	18
Chapter 5: Configuration Mode	21
Overview	21
Viewing & Changing M2 Rig Monitor Parameters	21

Chapter 6: Maintenance	24
Overview.....	24
Preventive Maintenance	24
Troubleshooting.....	25
Calibration Frequency.....	27
Calibration.....	27
Adjusting Strobe/Horn Volume	30
Replacing Components of the M2 Rig Monitor	31
Chapter 7: RS-485 Modbus Output	33
Overview.....	33
Wiring the M2 Rig Monitor in a Modbus System	33
Using the M2 Rig Monitor in a 4-wire Modbus System.....	35
Modbus Mode	35
Supported Modbus Functions	37
Parts List	43
Appendix A: Control Button Quick Reference Guide	44
Appendix B: Function Code 16 Registers	45
(Appendix B available from RKI Instruments, Inc. Not included in manual as normally provided with M2 Rig Monitor detector head.)	

Chapter 1: Introduction

Overview

This chapter briefly describes the M2 Rig Monitor. This chapter also describes the *M2 Rig Monitor Operator's Manual* (this document). Table 1 at the end of this chapter lists the specifications for the M2 Rig Monitor.

About the M2 Rig Monitor

The M2 Rig Monitor is a fixed mount, continuous-monitoring detector head. All user adjustable parameters may be accessed using push button switches. In addition, calibration may be performed non-intrusively by use of a magnetic wand accessory which activates magnetic switches through a window at the front face of the detector head.

The Rig Monitor displays the current gas reading on an LCD display which is visible through the window in the cover (front face) and provides a 4 - 20 mA signal which indicates the target gas reading for use by a gas monitoring controller, recording device, or programmable controller. The Rig Monitor also provides an RS-485 Modbus output. Three sets of relay contacts, two controlled by the gas alarms and one by the fail alarm, rated at 115 VAC 5 amps are available for controlling devices such as lights or horns or for controlling higher rated relays. The alarm 1 relay is factory wired to the strobe/horn.

Three operating modes allow you to display and change setup and calibration settings. They are Calibration Mode, Configuration Mode, and Modbus Mode.

About this Manual

The *M2 Rig Monitor Operator's Manual* uses the following conventions for notes, cautions, and warnings.

NOTE: Describes additional or critical information.

CAUTION: Describes potential damage to equipment.

WARNING: Describes potential danger that can result in injury or death.

Specifications

Table 1 lists specifications for the M2 Rig Monitor.

Table 1: M2 Rig Monitor Specifications

Target Gas/Detection Range	Hydrogen Sulfide (H ₂ S): 0 - 100 ppm, 1 ppm increments
Alarm Settings (Alarm 1/Alarm 2)	10 ppm/50 ppm
Construction (housing)	Explosion-proof Junction Box, NEMA 4
Sampling Method	Diffusion
Input Power	10.8 - 14.5 VDC
Controls	<ul style="list-style-type: none">• Three push button switches• Three magnetic switches for non-intrusive calibration
Weight	14 lbs.
Signal Output	<ul style="list-style-type: none">• 4 to 20 mA, 500 ohms impedance max• RS-485 Modbus
Accuracy	± 5% of reading or ± 2 ppm H ₂ S (whichever is greater)
* These are the RKI factory settings. You can change the alarm settings in Configuration Mode. See “Viewing & Changing M2 Rig Monitor Parameters” on page 21.	

WARNING: *When using the M2 Rig Monitor, you must follow the instructions and warnings in this manual to assure proper and safe operation of the M2 Rig Monitor and to minimize the risk of personal injury. Be sure to maintain and periodically calibrate the M2 Rig Monitor as described in this manual.*

WARNING: *M2 Rig Monitor detector heads with firmware version 5.0 or later have a different Modbus register assignment than M2 Rig Monitors with previous versions of firmware. If you are adding M2 Rig Monitors with firmware version 5.0 or later to an existing Modbus network installation, confirm what firmware version is installed in the M2 Rig Monitors already in the network and if necessary, take all steps required to address the differences in Modbus register assignments. See “Supported Modbus Functions” on page 37 for information on the current Modbus register assignments. The firmware version is shown on the Information Screen described on page 17.*

Chapter 2: Description

Overview

This chapter describes external and internal components of the M2 Rig Monitor.

External Description

This section describes the junction box and all external components of the M2 Rig Monitor.

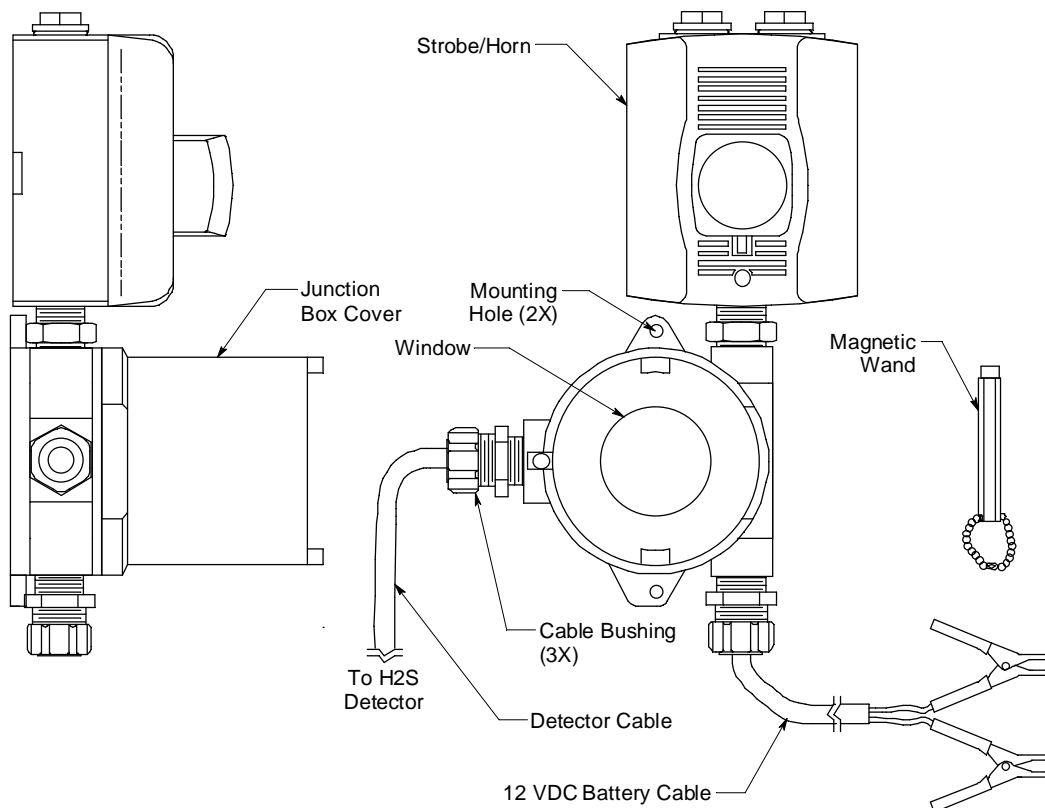

Figure 1: M2 Rig Monitor External Components

Rig Monitor Junction Box

The M2 Rig Monitor's cast aluminum junction box is dust and weather resistant. The junction box also protects the Rig Monitor and all connections made to it. Three 3/4 in. conduit hubs are used to connect the H₂S detector to the junction box (cable factory installed in the left hub), connect wiring from an external 12 VDC battery (cable factory installed in bottom hub) and to install the strobe/horn (factory installed in top hub).

Use the junction box's two mounting holes to mount the Rig Monitor to a vertical surface at the monitoring site. The window in the cover on the front of the junction box allows you to view the LCD display and use the magnetic wand to actuate the magnetic control switches so you can perform non-intrusive calibration. Removing the cover allows you to access the interior of the junction box.

Alarm Strobe/Horn

The Rig Monitor has a red alarm strobe light/horn installed in the top conduit hub. The Rig Monitor retains its NEMA 4 rating with the strobe installed. Strobe operation is controlled by the Alarm 1 relay contacts. The relay action settings can be changed in Configuration Mode.

Magnetic Wand

The magnetic wand is a short plastic rod with a magnet in one end. It is used to actuate the magnetic control switches on the control PCB while the junction box cover is still installed so that non-intrusive calibration can be performed.

H₂S Detector, Junction Box, and Cable

The H₂S detector consists of a junction box with a mounting bracket, the detector, and the calibration cup/splash guard.

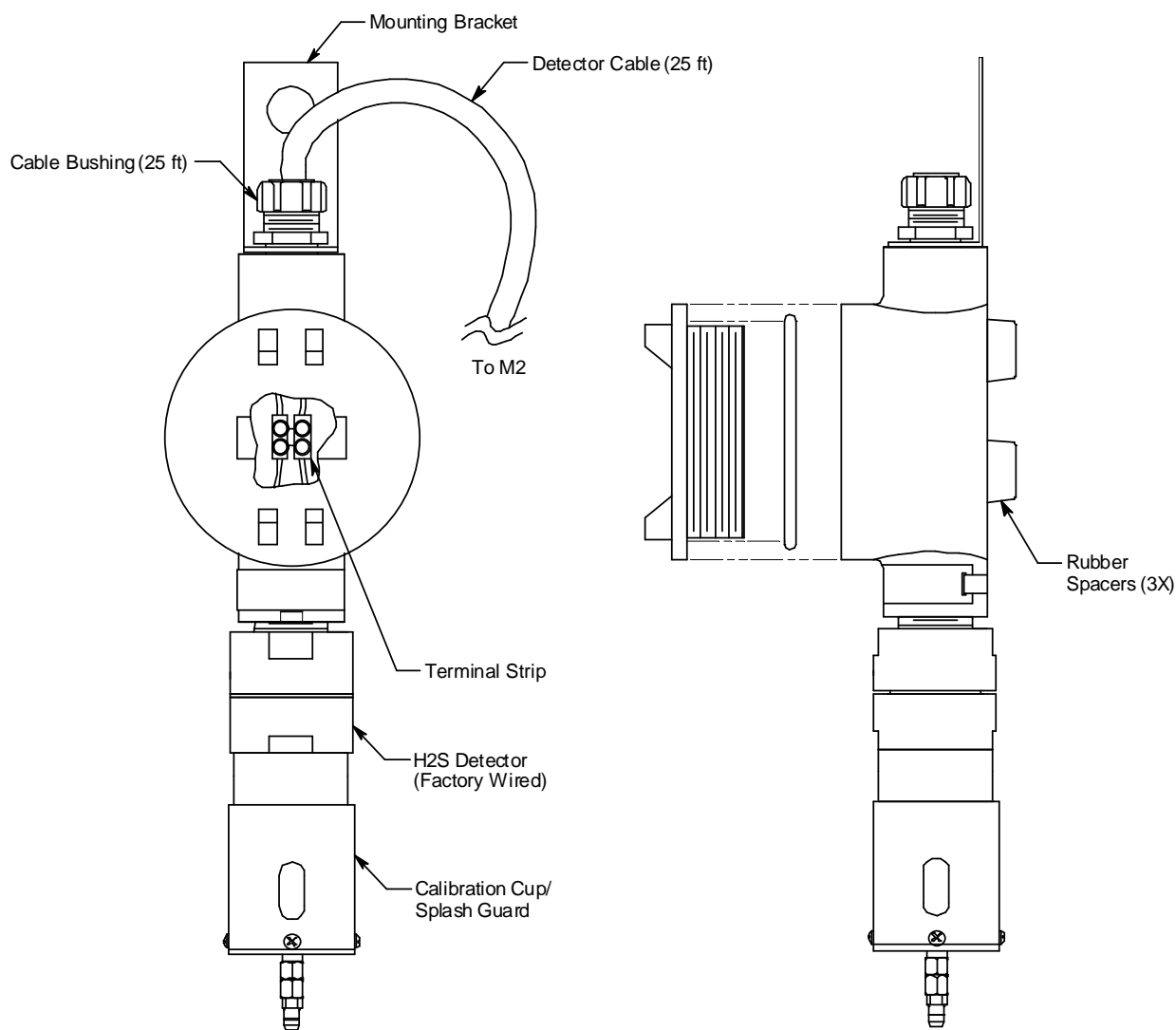

Figure 2: H₂S Junction Box Component Location

The H₂S detector is installed in the junction box's bottom conduit hub and is factory wired to the M2 through the left cable bushing in the M2 junction box with a 25 foot cable for remote installation. The mounting bracket at the top of the junction box is used to mount the junction box. The junction box protects the detector wiring connections. Three spacers installed on the back of the junction box control the distance of the junction box from a mounting surface and ensure that there is enough room to perform a calibration. A cover on the front of the junction box allows access to the interior of the junction box.

The detector housing body protects the sensing components within the housing. Use the removable cap near the bottom of the housing to access the sensor for maintenance or replacement. The cap protects the sensor from damage and includes a flame arrestor which contains any sparks which may occur within the detector housing. A cap gasket seals the interface between the housing and cap. A flame arrestor guard is permanently bonded to the cap.

The calibration cup/splash guard is screwed onto the bottom of the flame arrestor guard.

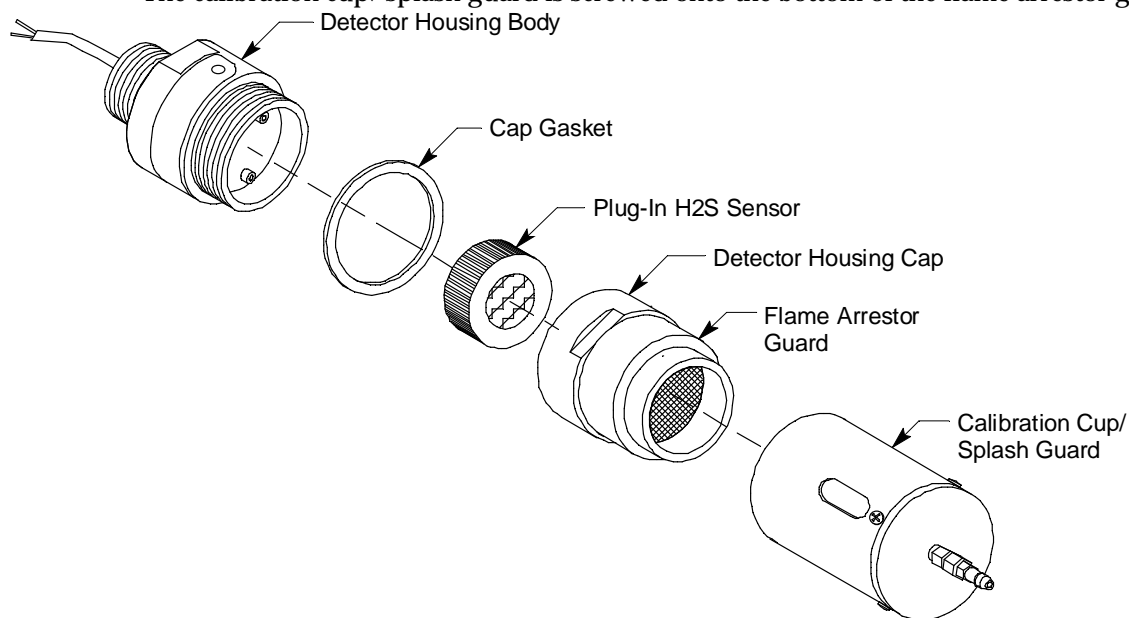

Figure 3: H₂S Detector Component Location

The sensor is secured within the sensor housing by four pins. Through a series of chemical and electrical reactions, the sensor produces an electrical output that corresponds to the detection range of the detector. A pre-amplifier, located between the sockets and two interconnect wires, conditions the sensor's signal before the signal reaches the controller.

12 VDC Battery Cable

A 50 foot cable with clamps for connection to a 12 VDC battery (customer supplied battery not included) is factory-wired through the bottom cable bushing of the M2. One end of the cable is connected to the power converter PCB.

Internal Description

This section describes the internal components of the M2 Rig Monitor. The internal components of the Rig Monitor include the terminal PCB which provides for all the wiring connections to the Rig Monitor and the control PCB which displays the gas reading and has the control buttons.

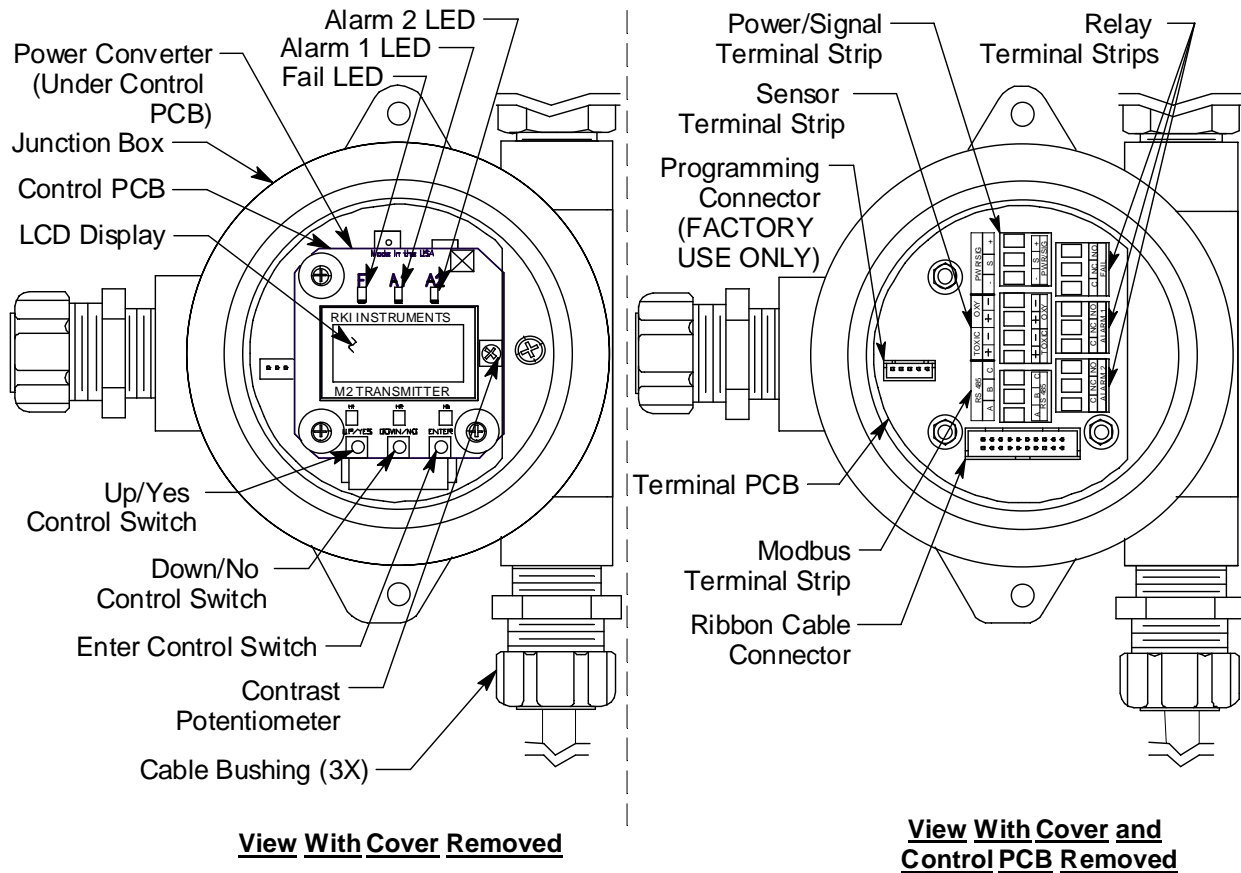

Figure 4: M2 Rig Monitor Internal Components

Power Converter

The power converter is located below the control PCB and is connected with standoffs that are permanently attached to the control PCB. The power converter takes 12 VDC voltage supplied to the Rig Monitor and converts it to 24 VDC which is used to run the Rig Monitor. The power converter includes a three point terminal strip for field connection of the 12 VDC supply and a recording device, gas-monitor controller, or programmable controller. The terminal strip is accessible when the control PCB is pulled away as described in “Wiring the M2 Rig Monitor” on page 12.

Terminal PCB

The terminal PCB is encapsulated in epoxy for protection against moisture and physical damage. It is mounted into the rear of the junction box with three standoffs and rests on a thin layer of foam. A banana jack is screwed into each of the standoffs and used for mounting the control PCB. The terminal PCB converts the electrical output from the detector to a signal which can be displayed by the LCD display, a 4 - 20 mA signal (that corresponds to the detection range), and an RS-485 Modbus output signal. The 4 - 20 mA

signal may be used by a recording device, gas monitor controller, or programmable controller. The Modbus output may be used to connect the Rig Monitor to a Modbus network. The terminal PCB also controls three relays, one fail and two gas alarm relays.

Two columns of plug-in style terminal strips are used to make all wiring connections to the terminal PCB. The column on the left consists of the power/signal, detector, and Modbus terminal strips. The column on the right consists of the relay terminal strips. A 20 position connector at the bottom of the terminal PCB is used to connect the terminal PCB to the control PCB with a ribbon cable. A 5 position connector on the left side of the terminal PCB is used by factory or field service personnel to program the Rig Monitor.

Power/Signal Terminal Strip

The power/signal terminal strip is a three position plug-in style terminal strip located at the top of the left terminal column. If is factory wired to the power converter and strobe/horn.

Detector Terminal Strip

The detector terminal strip is a four position plug-in style terminal strip and is the middle terminal strip in the left terminal column. Only the bottom 2 terminals are used for connecting the H₂S detector. It is factory wired to the H₂S detector.

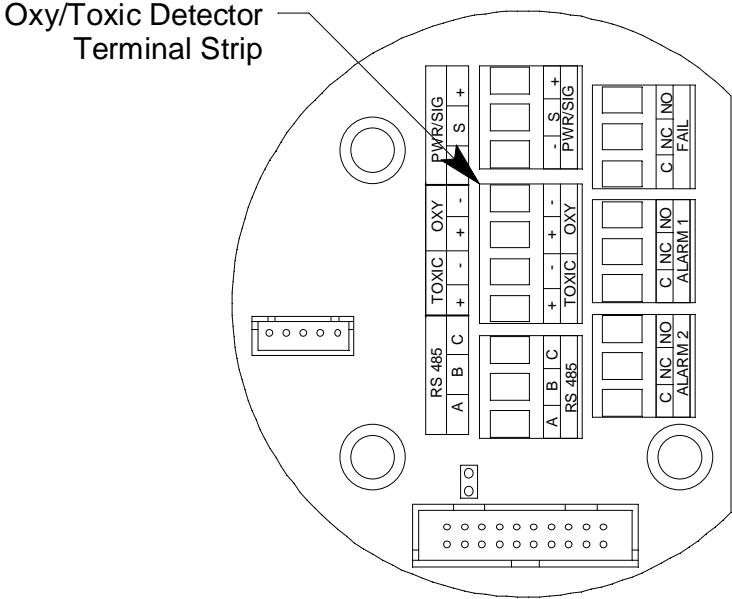

Figure 5: Detector Terminal Strip

Modbus Terminal Strip

The Modbus terminal strip is a three position plug-in style terminal strip and is the bottom terminal strip in the left terminal column. It allows connection of the Rig Monitor into a Modbus network.

Relay Terminal Strips

The right column of terminal strips consists of, from top to bottom, the fail, alarm 1, and alarm 2 relay terminal strips. They are three-position plug-in style terminal strips. The relay terminal strips are used to connect devices such as lights and horns that are controlled by the relay contacts. The relay contacts are rated at 115 VAC, 5 amps. The relay contacts may also be used to control higher rated relays. The Rig Monitor uses the Alarm 1 relay to control the factory installed strobe/horn. Only the Fail and Alarm 2 relays are available for customer use.

Termination Jumper

A two pin header with a termination jumper installed is located below the Modbus terminal strip. The jumper has no function unless the Rig Monitor is wired into a Modbus installation. See “Chapter 7: RS-485 Modbus Output” on page 33 for a description of using the Rig Monitor in a Modbus system.

Control PCB

The LCD display and control switches are located on the control PCB. It is installed on top of the terminal PCB by lining up its three spacing standoffs with the banana jacks in the terminal PCB mounting standoffs and pushing it onto the banana jacks. The jacks retain the control PCB.

The power converter is installed on the back of the control PCB with standoffs.

LCD Display

The LCD display is located at the top of the control PCB. It indicates the current gas reading and displays messages and parameters in the Rig Monitor’s programs.

Control Buttons

The Rig Monitor includes three push button switches that allow you to enter the Rig Monitor’s operating modes, navigate through the modes, update settings, and save changes to the settings. The push button switches are located along the bottom edge of the control PCB (see Figure 4). The UP/YES button is on the left, the DOWN/NO button is in the middle, and the ENTER button is on the right.

Table 2: M2 Rig Monitor Control Button Functions

Switch	Function
UP (YES)	<ul style="list-style-type: none">• Saves settings• Changes the displayed setting• Enters the Calibration Program• Enters Configuration Mode (press with ENTER button)
DOWN (NO)	<ul style="list-style-type: none">• Cancels setting changes• Changes the displayed setting• Enters Modbus Mode (press with ENTER button)• Displays the Information Screen
ENTER	<ul style="list-style-type: none">• Initiates operations• Enters Configuration Mode (press with UP/YES button)• Enters Modbus Mode (press with DOWN/NO button)• Functions as an alarm reset switch

Just above each push button switch is a magnetic switch with the same function as the push button switch below it. The magnetic switches are for use in non-intrusive

calibration. They are actuated by bringing the magnetic wand close enough to them to actuate them. Although the magnetic switches have the same functions as the push button switches, it is not practical to use them for operations other than calibration because it is not possible to actuate two magnetic switches at once with only one magnetic wand. Since displaying the Information Screen only requires the use of one switch, the wand may be used to show the Information Screen (see “Information Screen” on page 17).

Status LEDs

The Rig Monitor includes five status LEDs that are located above the display (see Figure 4).

- Fail LED
The fail LED turns on when the Rig Monitor is experiencing a fail condition. A fail condition can be caused by a detector failure or low detector signal.
- Alarm 1 LED
The alarm 1 LED is on when the Rig Monitor is experiencing an alarm 1 condition.
- Alarm 2 LED
The alarm 2 LED is on when the Rig Monitor is experiencing an alarm 2 condition.
- RX & TX LED's
These LED's indicate data being received (RX) and transmitted (TX) when the Rig Monitor's Modbus output is operating.

Chapter 3: Installation & Startup

Overview

This chapter describes procedures to mount the M2 Rig Monitor in the monitoring environment and wire it to input power and devices.

Mounting the M2 Rig Monitor

Perform the following procedure to install the instrument housing at the mounting site.

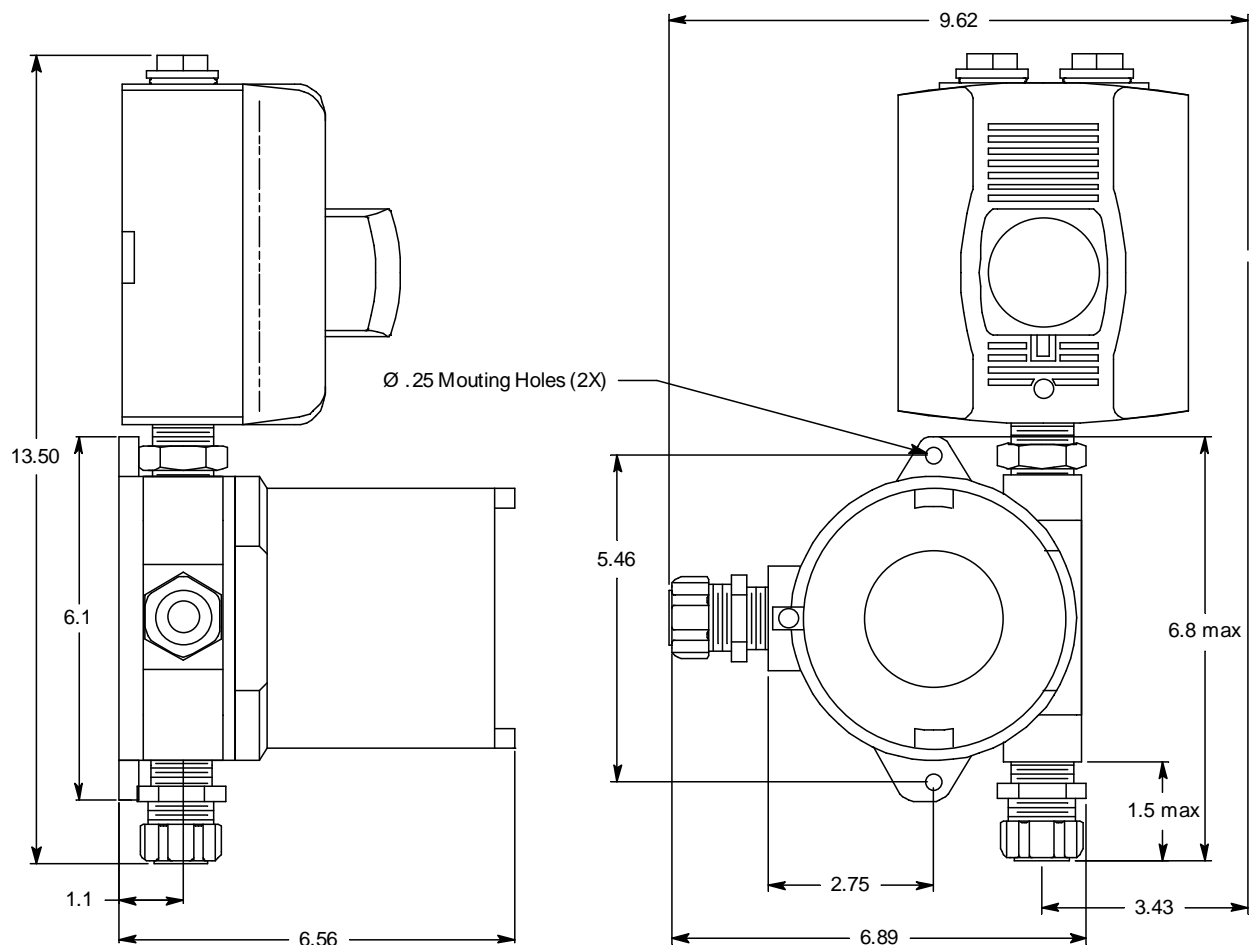

Figure 6: Rig Monitor Outline and Mounting Dimensions

1. Select a mounting site that is representative of the monitoring environment. Consider the following when you select the mounting site.
 - Select a site where the Rig Monitor is not likely to be bumped or disturbed. Make sure there is sufficient room to perform start-up, maintenance, and calibration procedures.
 - Is a DC power source available?

- Are the display screen and status lights on the Rig Monitor visible?
2. At the monitoring site, use #10 screws through the Rig Monitor junction box's two mounting holes to secure the junction box to a vertical surface. Figure 7 shows the outline and mounting dimensions for the Rig Monitor. Hang the H₂S detector junction box using the mounting bracket. Ensure that the detector is facing down.

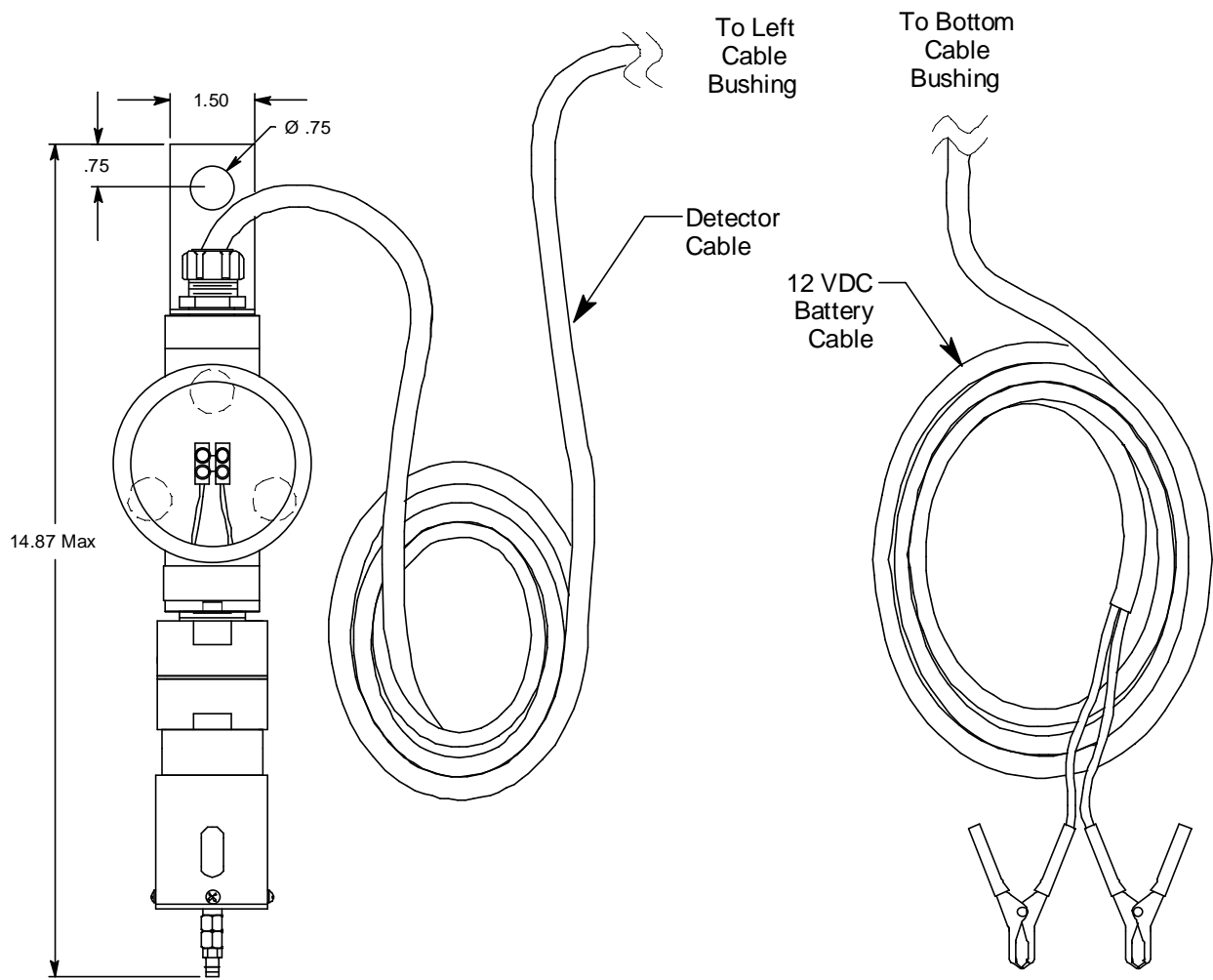

Figure 7: H₂S Junction Box Outline & Mounting Dimensions

Wiring the M2 Rig Monitor

WARNING: Always verify that the power source is OFF before making any wiring connections.

The detector leads, junction box connection, power cable wiring, and strobe/horn wiring are all factory wired as shown in the figure below.

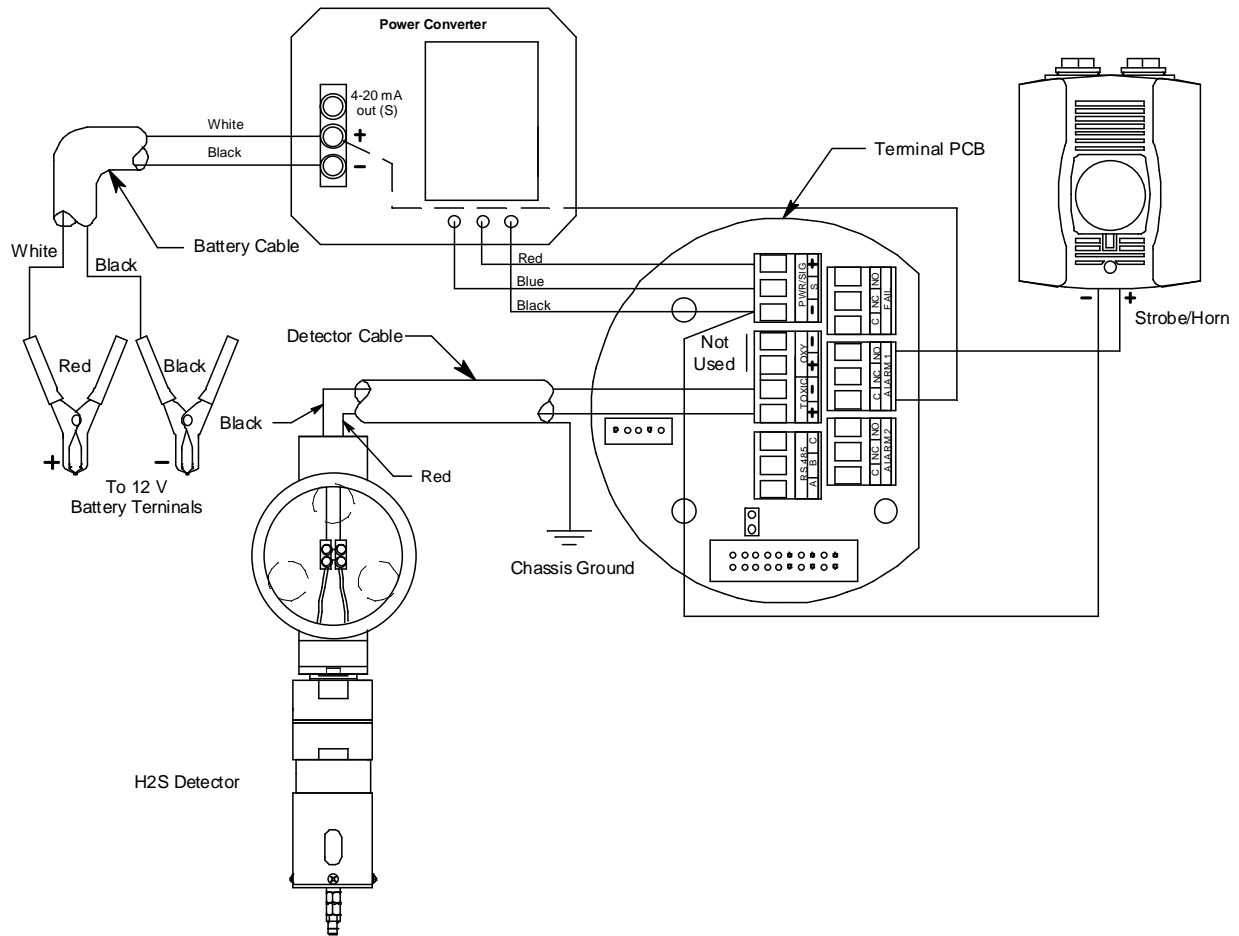

Figure 8: Rig Monitor Factory Wiring

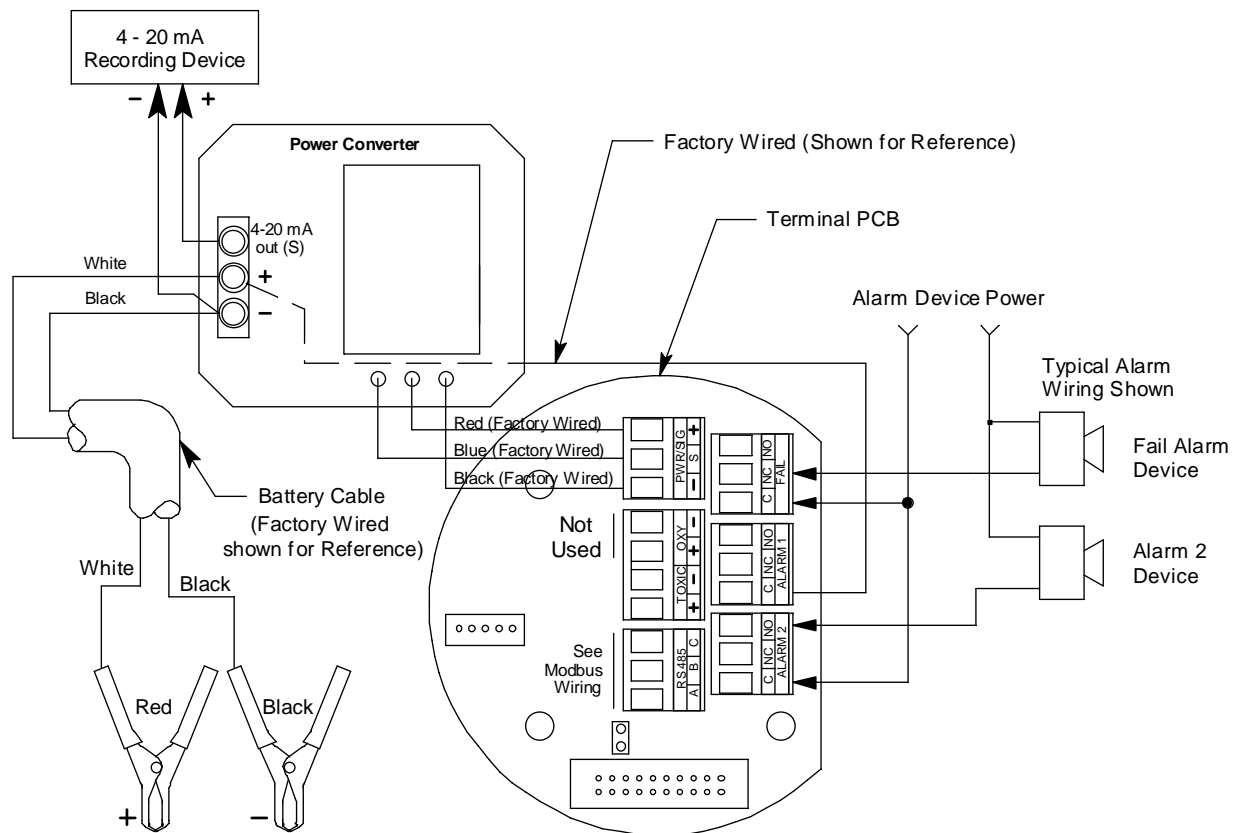

Figure 9: Rig Monitor Field Wiring

Connecting DC Power

Perform the following functions to connect the Rig Monitor to DC power. One end of the battery cable is already factory wired to the appropriate terminals at the Rig Monitor housing. Use the other end to connect a 12 VDC battery.

1. Connect the red battery clamp to the (+) terminal of the 12 VDC battery.
2. Connect the black battery clamp to the (-) terminal of the 12 VDC battery.

Connecting External Alarms

Perform the following procedure to connect external alarms to the Rig Monitor's Fail or Alarm 2 terminals. The Alarm 1 terminals are factory wired and are not available for field use.

1. Disconnect the battery clamps from the + and - terminals of the 12 VDC battery.
2. Remove the junction box cover.
3. Grasp the control PCB by its edges.
4. Gently pull until the control PCB is pulled away from the banana jacks. Take care not to pull too hard and damage the cable which connects the control and terminal PCB's.
5. Let the control PCB hang by the cable. The terminal strips are now visible on the terminal PCB. The control PCB may be left hanging while wiring is done.
6. Locate the relay terminal strips. See Figure 4 to assist you in locating the relay terminal strips.

7. All of the conduit hubs are used in the Rig Monitor so you will need to uninstall the power cable from the bottom conduit hub and install a junction box that has multiple conduit hubs. Install appropriately rated cable bushings in the junction box.

WARNING: *Use an appropriately rated junction, conduit, conduit fittings, and appropriate construction technique to maintain the NEMA 4 environmental rating of the M2 junction box and avoid water entering the junction box at the conduit hubs.*

8. Guide the power wiring through the new junction box to the Rig Monitor and reconnect it.
9. Guide the wiring of the external alarm through the new junction box to the Rig Monitor.
10. Connect the leads from the external alarm to the appropriate terminals on the appropriate relay terminal strip as shown in Figure 9 to obtain the desired operation.
11. Repeat steps 8 and 9 for an additional alarm device.
12. Re-install the control PCB. Be sure the ribbon cable is routed down below the control PCB so it will not be damaged by the cover when it is screwed back on.
13. Secure the junction box cover to the junction box.

Connecting Recorders

Perform the following procedures to connect an analog signal recording device to the Rig Monitor. The output at the 4-20 mA out terminals is a 4-20 mA signal that corresponds to the detection range of the H₂S detector.

1. Disconnect the battery clamps from the + and - terminals of the 12 VDC battery.
2. Remove the junction box cover.
3. Grasp the control PCB by its edges.
4. Gently pull until the control PCB is pulled away from the banana jacks. Take care not to pull too hard and damage the cable which connects the control and terminal PCB's.
5. Let the control PCB hang by the cable. The terminal strips are now visible on the terminal PCB. The control PCB may be left hanging while wiring is done.
6. Locate the 4-20 mA out terminals on the power converter below the control PCB. See Figure 9 to assist you in locating the recorder output terminals. They are labelled **4-20 mA out (S)** and **-**.
7. All of the conduit hubs are used in the Rig Monitor so you will need to uninstall the power cable from the bottom conduit hub and install a junction box that has multiple conduit hubs. Install appropriately rated cable bushings in the junction box.

WARNING: *Use appropriately rated junction box, conduit, conduit fittings, and appropriate construction technique to maintain the NEMA 4 environmental rating of the M2 junction box and avoid water entering the junction box at the conduit hubs.*

8. Guide the power wiring through the new junction box to the Rig Monitor and reconnect it.
9. Guide the wiring from the recording device through the new junction box to the Rig Monitor.

10. Connect the leads from the recording device to the 4-20 mA out terminal strip as shown in Figure 9. When connecting to the - terminal, take care to maintain the existing factory wiring to the - terminal.
11. Re-install the control PCB. Be sure the ribbon cable is routed down below the control PCB so it will not be damaged by the cover when it is screwed back on.
12. Secure the junction box cover to the junction box.

Wiring into a Modbus Network

If you wish to wire the Rig Monitor into a Modbus network, see “Wiring the M2 Rig Monitor in a Modbus System” on page 33.

Start Up

Introducing Incoming Power

1. Complete the installation procedures described earlier in this manual.
2. Verify that all wiring connections are correct and secure.
3. Connect the battery clamps to the + and - terminals of the 12 VDC battery.
4. The LCD display will indicate the firmware version when the Rig Monitor is first powered up and will then count down a one minute warm-up period before normal operation begins. During normal operation, the display will indicate the target gas and current gas reading. Verify that the display is indicating the target gas and current gas reading after the warm-up period is complete and normal operation begins.

H2S 0 ppm

NOTE: Allow the Rig Monitor’s detector to warm up for 15 minutes before you continue with the next section, “Adjusting the Fresh Air Reading.”

Adjusting the Fresh Air Reading

When the Rig Monitor is shipped from RKI Instruments, Inc., it is factory calibrated. If a full calibration is desired at startup, see “Calibration” on page 27.

Verify that the Rig Monitor is in a fresh air environment (environment known to be free of H₂S and of normal oxygen content, 20.9%).

CAUTION: *If you suspect the presence of H₂S, use the calibration kit and the zero air calibration cylinder to introduce “fresh air” to the detector and verify an accurate fresh air setting. See “Calibration” on page 27 for instructions on how to use a zero air cylinder when performing a fresh air adjustment.*

Non-Intrusive Fresh Air Signal Adjustment

If you wish to adjust the fresh air reading without removing the Rig Monitor’s junction box cover, use the magnetic wand accessory to actuate the magnetic switches instead of pushing the control switch buttons. To actuate a magnetic switch and perform the same operation as pressing a control switch button, touch the magnet in the end of the magnetic wand to the Rig Monitor’s glass cover directly over the magnetic switch you wish to

actuate. Touching the glass and removing the wand is the same as pressing and releasing a button. Touching the glass and keeping the wand in place is the same as pressing and holding a button.

WARNING: *The M2 Rig Monitor is not an active gas monitoring device during the fresh air adjustment procedure. The 4-20 mA output signal will “freeze” at 3.5 mA and all relays will remain in their non-alarm state while the M2 Rig Monitor is in Calibration Mode. The output signal will not indicate current readings and the relays will not resume operating normally until the M2 Rig Monitor is in normal operation again.*

NOTE: While in the calibration program, if there is no switch activity for the calibration time-out period the unit will return to normal operation. The factory set time-out is 15 minutes. If you want a different time-out period, see “Viewing & Changing M2 Rig Monitor Parameters” on page 21 for instructions to change the calibration time-out.

Adjusting the Fresh Air Reading

1. While in normal operation, press and hold the UP/YES button for 5 seconds to enter Calibration Mode. Release the button when the following screen appears.

Calib? YES/NO

2. Press and release the UP/YES button to continue. The display will indicate the target gas and **CAL Mode** for a few seconds before showing **FreshAir Adjust?**.
3. Press and release the UP/YES button. **ENTER** will alternate with **FreshAir** on the top display line and the current gas reading will be on the bottom display line.
4. Press and release the ENTER button. The M2 Rig Monitor will perform a zero operation and the display will indicate **SPAN w/Cal Gas?**.
5. Press and release the DOWN/NO button. The display will indicate **Leaving CAL Mode** and the M2 Rig Monitor will return to normal operation.

Chapter 4: Operation

Overview

This chapter describes the M2 Rig Monitor in normal operation. This chapter also describes the Rig Monitor in alarm 1, alarm 2, and fail conditions and suggests responses to these conditions.

Normal Operation

Normal operation is defined as follows:

- The start-up procedure is complete.
- The Rig Monitor is not indicating an alarm 1, alarm 2, or fail condition.
- The Rig Monitor is not in Calibration or Configuration modes.

During normal operation, the Rig Monitor simultaneously displays the current gas reading, unit of measure, and target gas.

H2S 0 ppm

Information Screen

The Information Screen displays the M2 Rig Monitor's operating voltage and firmware and hardware information. To display the Information Screen, do the following:

1. Press and hold the DOWN/NO button for 3 seconds. The Information Screen will appear.

24.2V v5.0 2B

2. Continue holding the DOWN/NO button to keep the Information Screen on the display. The top line indicates the voltage that the power converter is providing to the Rig Monitor. The second line indicates the firmware that is running, version 5.0 in this example, and the Rig Monitor's hardware version, version 2B in this example. This information may be useful if you need to contact the factory with questions about the Rig Monitor.
3. Release the DOWN/NO button when you are done viewing the Information Screen. The display will return to the normal operation screen within a couple of seconds.

NOTE: The Information Screen is not a good indicator of battery life because the power converter will operate as normal and have an output of 24 volts until the 12 VDC battery dies.

4 - 20 mA Signal Output Operation

The output at the S terminal of the power/signal terminal strip is a 4 - 20 mA signal that corresponds to the detection range of the M2 Rig Monitor. During normal operation, this signal tracks the gas concentration on the LCD.

There are several circumstances where the signal output will not track the display reading but will behave as follows:

- When the Rig Monitor is in its warm-up period, the signal output will be fixed at 3.5 mA (zero).
- If you enter Calibration Mode, Configuration Mode, or Modbus Mode, the signal output will be fixed at 3.5 mA until the Rig Monitor returns to normal operation.
- If the Rig Monitor's input power decreases below 10 volts so that the Rig Monitor is in a low power alarm, the signal output is fixed below 2.4 mA until the low power alarm is cleared.

NOTE: Under typical operating conditions, there may be no low power alarm. The 12 VDC battery that is recommended for operation may fail before the power converter recognizes a low power condition.

- If the Rig Monitor goes into a fail condition, after a 30 second delay, the signal output is fixed below 2.4 mA until the fail alarm is cleared.

Alarm Indications

NOTE: The M2 Rig Monitor includes alarm on and alarm off delay settings for alarm 1 and alarm 2. The alarm indications described in this section operate according to the factory set alarm settings. See Table 4 on page 22 for all the factory settings.

Table 3: Visual and Audible Alarm Indications

Condition	Cause	Visual Indication(s)
Alarm 1 ¹	Increasing gas reading at or above the alarm 1 setpoint	<ul style="list-style-type: none">• A1 LED is on• Gas reading alternates with ALARM-1 message• Strobe/horn activates
Alarm 2 ¹	Increasing gas reading at or above the alarm 2 setpoint	<ul style="list-style-type: none">• A2 LED is on• Gas reading alternates with ALARM-2 message
Fail	<ul style="list-style-type: none">• Disconnected or misconnected detector wiring• Display reading at -10% of full scale or lower• Defective components	<ul style="list-style-type: none">• F LED is on• FAIL message replaces gas reading <p><i>NOTE: There is a 30 second delay on the fail condition.</i></p>

Table 3: Visual and Audible Alarm Indications

Condition	Cause	Visual Indication(s)
Low Power	DC power source less than 18.5 volts.	<ul style="list-style-type: none"> • F LED is on • LowPower message and actual voltage of incoming DC power
<p><i>NOTE: Under typical operating conditions, there may be no low power alarm. The 12 VDC battery that is recommended for operation may fail before the power converter recognizes a low power condition.</i></p>		
<p><i>* ¹If the M2 Rig Monitor is in both an alarm 1 and an alarm 2 condition, both alarm LEDs are on and the display alternates between the gas reading and the ALMS 1&2 message.</i></p>		

NOTE: You can select normally energized (N. EN) or normally de-energized (N. DE-EN) alarm 1 and alarm 2 relay settings in Configuration Mode. The following sections describe the standard factory setting for these relays which is N. DE-EN.

The fail relay is factory set as N. EN and is not user-adjustable.

Alarm 1 Condition

Alarm 1 Condition Indications

When the gas reading reaches the alarm 1 setpoint, the Rig Monitor senses an alarm 1 condition. The Rig Monitor alerts you to an alarm 1 condition as follows:

- The A1 LED turns on.
- The gas reading alternates with the **ALARM-1** message.
- The alarm 1 relay energizes and the strobe/horn activates.

Responding to an Alarm 1 Condition

1. Follow your established procedure for a low level H₂S condition.
2. After the gas reading falls below the alarm 1 setpoint, press the ENTER button to reset the alarm 1 circuit. Resetting the alarm 1 circuit turns off the A1 LED, resets the LCD, de-energizes the alarm 1 relay, and turns off the strobe/horn.

NOTE: If the ENTER button is pressed while the M2 Rig Monitor is in an alarm 1 condition, the A1 LED will flash but all other indications will remain unchanged.

You cannot de-energize the alarm 1 relay, and consequently the strobe/horn, until the gas reading falls below the alarm 1 setpoint.

Alarm 2 Condition

Alarm 2 Condition Indications

When the gas reading reaches the alarm 2 setpoint, the Rig Monitor senses an alarm 2 condition. The Rig Monitor alerts you to an alarm 2 condition as follows:

- The A2 LED turns on.
- The gas reading alternates with the **ALARM-2** message.
- The alarm 2 relay energizes.

NOTE: If the M2 Rig Monitor is in both an alarm 1 and alarm 2 condition, both the A1 and A2 LEDs will be on, the gas reading will alternate with the **ALMS 1&2** message, and both alarm relays will energize.

Responding to an Alarm 2 Condition

1. Follow your established procedure for a high level H₂S condition.
2. After the gas reading falls below the alarm 2 setpoint, press the ENTER button to reset the alarm circuit. Resetting the alarm circuit turns off the A2 light, resets the LCD, and de-energizes the alarm 2 relay.

NOTE: If the ENTER button is pressed while the M2 Rig Monitor is in an alarm 2 condition, the A2 LED will flash but all other indications will remain unchanged.

You cannot de-energize the alarm 2 relay until the gas reading falls below the alarm 2 setpoint.

Fail Condition

Fail Condition Indications

The Rig Monitor indicates a fail condition for any of the following:

- The detector wiring is disconnected or incorrectly connected.
- The display reading is -10% of full scale or lower.

When the Rig Monitor senses a fail condition, it alerts you as follows:

- The F LED turns on.
- The gas reading is replaced by the **FAIL** message.
- The fail relay de-energizes.

NOTE: The fail alarm has a 30 second delay.

Responding to a Fail Condition

1. Verify that the detector wiring is correctly and securely connected.
2. Verify that the replaceable plug-in sensor in the detector housing is properly installed.

Low Power Condition

The 12 VDC battery that is recommended for operation of the Rig Monitor is typically dead before the power converter recognizes a low power condition. As a result, when the Rig Monitor is used with a 12 VDC battery, there will be no low power alarm and the unit will instead shut off once the battery is dead.

Chapter 5: Configuration Mode

Overview

This chapter describes how to view and change M2 Rig Monitor parameters using Configuration Mode. It is accessed using the program buttons.

Configuration Mode includes a 5-minute time-out feature. If you do not press a control button for 5 minutes, the Rig Monitor automatically returns to normal operation.

NOTE: If the M2 Rig Monitor returns to normal operation because of a time-out, it enters a warm-up period just as it does when it is first turned on.

If you are installing a new M2 Rig Monitor, it has been setup at the factory. Use Configuration Mode only if you want to change the M2 Rig Monitor's setup.

Viewing & Changing M2 Rig Monitor Parameters

1. While in normal operation, simultaneously press and hold the UP/YES and ENTER buttons for 5 seconds to enter Configuration Mode. Release the buttons when the following screen appears.

Enter
Config?

2. If you want to exit Configuration Mode, press and release the DOWN/NO button and the Rig Monitor will return to normal operation.

If you want to continue in Configuration Mode, press and release the UP/YES button. The target gas and the full scale will be displayed for a few seconds before the first adjustable parameter, the alarm 1 setpoint, is displayed.

3. If you want to change the currently displayed parameter, use the UP/YES and DOWN/NO buttons to adjust it to the desired setting, then press ENTER to continue to the next parameter.

If the currently displayed parameter is OK, press the ENTER button to proceed to the next parameter.

Table 4 lists the Rig Monitor parameters you can set. Table 4 also lists the factory set value for each parameter.

Table 4: Configuration Parameters

Parameter (Factory Set Value)	Description
ALARM-1 (10 ppm)	The gas reading at which the Rig Monitor initiates an alarm 1 condition.
ALARM-1 (activation) (Increase)	Indicates if the alarm 1 circuit is activated by gas readings increasing (Increase) or decreasing (Decrease) to the ALARM-1 Level. <i>Note: Changing this parameter will affect the operation of the factory installed strobe/horn. Do not change this parameter from the factory setting.</i>
ALARM-1 (relay action) (N. DE-EN)	If set as N. DE-EN , the alarm 1 relay is de-energized in normal operation and energizes when an alarm 1 condition is initiated. If set as N. EN , the alarm 1 relay is energized in normal operation and de-energizes when an alarm 1 condition is initiated. <i>Note: Changing this parameter will affect the operation of the factory installed strobe/horn. Do not change this parameter from the factory setting.</i>
ALARM-1 (relay reset) (LATCH)	If set as LATCH , you must press the ENTER button to reset the alarm 1 circuit after the alarm 1 condition passes. If set as SELF-RST , the Rig Monitor automatically resets the alarm 1 circuit after the alarm 1 condition passes.
A1 OnDy (alarm 1 on delay) (1 secs)	The amount of time the Rig Monitor delays activation of the alarm 1 circuit once an alarm 1 condition is initiated. It can be set in 1 second increments from 0 - 60 seconds, in 1 minute increments from 1 - 15 minutes, and in 15 minute increments from 15 - 60 minutes.
A1 OffDy (alarm 1 off delay) (0 sec.)	The amount of time the Rig Monitor delays turning off the alarm 1 circuit once an alarm 1 condition passes. This parameter appears only if the alarm 1 relay reset setting is set to SELF-RST . It can be set in 1 second increments from 0 - 60 seconds, in 1 minute increments from 1 - 15 minutes, and in 15 minute increments from 15 - 60 minutes.
ALARM-2 (50 ppm)	The gas reading at which the Rig Monitor initiates an alarm 2 condition.
ALARM-2 (activation) (Increase)	Indicates if the alarm 2 circuit is activated by gas readings increasing (Increase) or decreasing (Decrease) to the ALARM-1 Level.
ALARM-2 (relay action) (N. DE-EN)	If set as N. DE-EN , the alarm 2 relay is de-energized in normal operation and energizes when an alarm 2 condition is initiated. If set as N. EN , the alarm 2 relay is energized in normal operation and de-energizes when an alarm 2 condition is initiated.
ALARM-2 (relay reset) (LATCH)	If set as LATCH , you must press the ENTER button to reset the alarm 2 circuit after the alarm 2 condition passes. If set as SELF-RST , the Rig Monitor automatically resets the alarm 2 circuit after the alarm 2 condition passes.
A2 OnDy (alarm 2 on delay) (1 secs)	The amount of time the Rig Monitor delays activation of the alarm 2 circuit once an alarm 2 condition is initiated. It can be set in 1 second increments from 0 - 60 seconds, in 1 minute increments from 1 - 15 minutes, and in 15 minute increments from 15 - 60 minutes.

Table 4: Configuration Parameters (Continued)

Parameter (Factory Set Value)	Description
A2 OffDy (alarm 2 off delay) (0 sec.)	The amount of time the Rig Monitor delays turning off the alarm 2 circuit once an alarm 2 condition passes. This parameter appears only if the alarm 2 relay reset setting is set to SELF-RST . It can be set in 1 second increments from 0 - 60 seconds, in 1 minute increments from 1 - 15 minutes, and in 15 minute increments from 15 - 60 minutes.
ZeroSupp (2 ppm)	The zero suppression feature helps prevent “jumpy” readings near the fresh air reading. For example, if the zero suppression setting for the H ₂ S detector is 2.0 ppm , the Rig Monitor will display a reading of 0 ppm for gas readings from -2 ppm to 2 ppm.
FILTER (5 secs)	The filter feature helps “smooth out” jumpy or noisy signals from the detector. You can set the filter from 0 seconds to 60 seconds in 5 seconds increments. The displayed gas reading is the average reading over the previous time period defined by the filter setting. So if the filter is set to 5 seconds, the displayed gas reading is the average over the past 5 seconds.
CAL Time (15 mins)	The calibration time-out sets the amount of time after the last button push while in Calibration Mode that the Rig Monitor will wait before returning to normal operation. If the calibration time-out is set to 15 mins , then Rig Monitor will return to normal operation automatically 15 minutes after the last button push.
Auto Zero (Enabled)	If set to Enabled , the Rig Monitor’s firmware will monitor the zero (fresh air) reading and make automatic zero adjustments under precisely specified conditions if it determines that a reading change is due to normal sensor drift. If set to Disabled , the Auto Zero function is turned off.

4. When you have scrolled through all the adjustable parameters, **SAVE IT? YES/NO** appears on the display.
5. If you do not wish to save the adjustments and want to exit Configuration Mode, press and release the DOWN/NO button. The **DO OVER? YES/NO** message will display. Press and release the DOWN/NO button. The **ABORT? YES/NO** message will display. Press the UP/YES button to return to normal operation.

If you wish to change some of the adjustments made, press and release the DOWN/NO button. The **DO OVER? YES/NO** message will display. Press and release the UP/YES button. The **Re-do Config** message will display and the M2 Rig Monitor will return to the first adjustable parameter. Go back to step 3 and continue.

If you wish to save the adjustments made, press and release the UP/YES button. **Config Saved** is indicated on the display for a few seconds and the M2 Rig Monitor returns to normal operation.

Chapter 6: Maintenance

Overview

This chapter describes procedures for performing preventive maintenance, troubleshooting, calibrating the M2 Rig Monitor, and replacing field replaceable parts.

Preventive Maintenance

This section describes a recommended preventive maintenance schedule to ensure the optimum performance of the M2 Rig Monitor. It includes daily, monthly, and quarterly procedures.

Daily

Verify a display reading of 0 ppm. Investigate significant changes in the reading.

Monthly

This procedure describes a test to verify that the Rig Monitor responds properly to the target gas.

NOTE: Performing a response test on the M2 Rig Monitor may cause alarms. If you do not want external alarms to actuate, disable any external alarms during the response test to avoid unwanted external alarm indications.

NOTE: The following procedure assumes the use of a calibration kit which includes a calibration gas cylinder, a fixed flow regulator with an on/off knob, and a short piece of sample tubing to connect the regulator to the calibration cup.

1. While in normal operation, press and hold the UP/YES button for 5 seconds and press the UP/YES button again when asked if you would like to enter Calibration Mode.
2. Connect the calibration kit sample tubing to the calibration cup/splash guard hose barb.
3. Connect the fixed flow regulator to the calibration cup/splash guard using the sample tubing.
4. Screw the calibration gas cylinder onto the fixed flow regulator.
5. Turn the regulator knob counterclockwise to open the regulator.
6. Allow calibration gas to flow for one minute.
7. Verify that the display reading is within $\pm 20\%$ of the gas concentration.

NOTE: If the reading is not within $\pm 20\%$ of the gas concentration, calibrate the M2 Rig Monitor as described in “Calibration” on page 27.

8. Turn the regulator knob clockwise to close the regulator.
9. Unscrew the calibration gas cylinder from the fixed flow regulator and disconnect the

sample tubing from the calibration cup/splash guard hose barb.

10. When the Rig Monitor display reading falls below the alarm setpoints, return it to normal operation.

11. Store the components of the calibration kit in a safe place.

Quarterly

Calibrate the Rig Monitor as described in “Calibration” on page 27.

Troubleshooting

The troubleshooting guide describes symptoms, probable causes, and recommended action for problems you may encounter with the M2 Rig Monitor.

Table 5: Troubleshooting the M2 Rig Monitor

Condition	Symptom(s)	Probable Causes	Recommended Action
No Power	The display backlight is off and the display screen is blank.	<ul style="list-style-type: none"> The power wiring at the Rig Monitor is disconnected or misconnected. The display cable is disconnected or misconnected. The battery is dead or at a very low voltage. 	<ol style="list-style-type: none"> Verify that the wiring to the power source is correct and secure. Verify that the ribbon cable connecting the terminal PCB to the control PCB is securely installed. This ribbon cable plugs into a connector on the top edge of the control PCB and on the bottom of the terminal PCB. If the power difficulties continue, contact RKI for further instruction.
Frequent or Suspect Alarms	The Rig Monitor alerts you to frequent or suspect alarms while the fresh air readings remain on zero.	<ul style="list-style-type: none"> The Rig Monitor is experiencing false readings due to RFI or EMI. The detector wiring is disconnected, misconnected, or intermittent. 	<ol style="list-style-type: none"> Verify that the Rig Monitor wiring is properly shielded. See “Wiring the M2 Rig Monitor” on page 12. Verify that the detector wiring is correct and secure. Increase the alarm on delay setting in Configuration Mode. If the frequent or suspect alarm difficulties continue, contact RKI for further instruction.
Flickering Display	The display reading flickers often.	<ul style="list-style-type: none"> The Rig Monitor is experiencing false readings due to RFI or EMI. The noise filter setting is too low. The zero suppression setting is too low. The display screen is malfunctioning. 	<ol style="list-style-type: none"> Verify that the Rig Monitor wiring is properly shielded. See “Wiring the M2 Rig Monitor” on page 12. Verify that the detector wiring is correct and secure. Increase the filter setting in Configuration Mode. Increase the zero suppression setting in Configuration Mode. If the display difficulties continue, contact RKI for further instruction.

Table 5: Troubleshooting the M2 Rig Monitor

Condition	Symptom(s)	Probable Causes	Recommended Action
Strobe/ Horn Not Working	<ul style="list-style-type: none"> The strobe/horn does not activate when an alarm 1 condition occurs. 	<ul style="list-style-type: none"> The strobe/horn is malfunctioning. The strobe/horn wiring is disconnected or misconnected. 	<ol style="list-style-type: none"> Verify that the strobe/horn is wired properly to the alarm terminal strip. If the strobe/horn difficulties continue, contact RKI for further instruction.
Fail Condition	<ul style="list-style-type: none"> Rig Monitor indicates a fail condition. 	<ul style="list-style-type: none"> The detector wiring to the terminal PCB is disconnected or misconnected. The plug-in H₂S sensor is not properly plugged into the sockets in the detector housing body. The detector fresh air signal is low enough to cause a fail condition. The detector is malfunctioning. The terminal or display PCB is malfunctioning. 	<ol style="list-style-type: none"> Verify that the detector wiring is correct and secure. Confirm that the plug-in H₂S sensor is installed properly. Calibrate the Rig Monitor. If the fail condition continues, replace the detector. If the fail condition continues, contact RKI for further instruction.
Slow or No Response/ Difficult or Unable to Calibrate	<ul style="list-style-type: none"> Rig Monitor responds slowly or does not respond to response test. Unable to successfully set the fresh air or span reading during calibration. Rig Monitor requires frequent calibration. <p><i>Note: Under "normal" circumstances, the detector requires calibration once every 3 months. Some applications may require a more frequent calibration schedule.</i></p>	<ul style="list-style-type: none"> The calibration cylinder is low, out-dated, or defective. The flame arrestor in the detector housing cap is wet or clogged with dirt or other particulates. The detector is malfunctioning. The terminal PCB is malfunctioning. 	<ol style="list-style-type: none"> Verify that the calibration cylinder contains an adequate supply of a fresh test sample. Verify that the calibration gas concentration is appropriate for the detector. Zero emission air (0 ppm H₂S) is normally used for a zero adjustment if the environment is suspect and 25 PPM H₂S in nitrogen is normally used for a response adjustment. Check the detector housing cap to determine if the flame arrestor is wet or dirty. Clean if necessary. If the calibration/response difficulties continue, replace the detector. If the calibration/response difficulties continue, contact RKI for further instruction.

Calibration Frequency

Although there is no particular calibration frequency that is correct for all applications, a calibration frequency of every 3 to 6 months is adequate for most Rig Monitor applications. Unless experience in a particular application dictates otherwise, RKI Instruments, Inc. recommends a calibration frequency of every 3 months.

If an application is not very demanding, for example detection in a clean, temperature controlled environment where H₂S is not normally present, and calibration adjustments are minimal at calibration, then a calibration frequency of every 6 months is adequate.

If an application is very demanding, for example if H₂S is present often and in significant concentrations or the environment is not well controlled, then more frequent calibration than every 3 months may be necessary.

Calibration

This section describes how to calibrate the M2 Rig Monitor. It includes procedures to prepare for calibration, enter Calibration Mode, adjust the fresh air (zero) setting, adjust the span setting, and return to normal operation.

WARNING: *The M2 Rig Monitor is not an active gas monitoring device during the calibration procedure. The 4-20 mA output signal will “freeze” at 3.5 mA and all relays will remain in their non-alarm state while the M2 Rig Monitor is in Calibration Mode. The output signal will not indicate current readings and the relays will not resume operating normally until the M2 Rig Monitor is in normal operation again.*

Non-Intrusive Calibration

If non-intrusive calibration is required, follow the instructions below, but do not remove the junction box cover. Use the magnetic wand accessory to actuate the magnetic switches instead of pushing the control switch buttons. To actuate a magnetic switch and perform the same operation as pressing a control switch button, touch the magnet in the end of the magnetic wand to the Rig Monitor’s glass cover directly above the magnetic switch you wish to actuate. Touching the glass and removing the wand is the same as pressing and releasing a button. Touching the glass and keeping the wand in place is the same as pressing and holding a button.

Calibration Gas Response Memory Feature

The Rig Monitor has the capability to “remember” the detector’s response to the calibration gas after the gas is removed from the detector during the fresh air and span adjustment procedure. This feature enables one person to perform calibration if the detector is mounted remotely from the Rig Monitor. When zero air is applied to the H₂S detector during a fresh air adjustment, the Rig Monitor will freeze the display reading at the lowest response and the Rig Monitor will continue to display this reading and retain it in its memory until the fresh air adjustment procedure is completed. When calibration gas is applied to the H₂S detector during a span adjustment, the Rig Monitor will freeze the display reading at the highest response to the calibration gas. The calibration gas can then be removed and the Rig Monitor will continue to display this reading and retain it in its memory until the span adjustment procedure is completed.

Preparing for Calibration

NOTE: The following procedure assumes the use of a calibration kit which includes a calibration gas cylinder, a zero air cylinder, a fixed flow regulator with an on/off knob, and a short piece of sample tubing to connect the regulator to the calibration cup/splash guard.

NOTE: While in the calibration program, if there is no switch activity for the calibration time-out period the unit will return to normal operation. See “Viewing & Changing M2 Rig Monitor Parameters” on page 21 for instructions to set the calibration time-out.

NOTE: The following procedure assumes that the target gas is present in a high enough concentration to affect the fresh air (zero) reading. If a fresh air environment can be verified, applying zero air to the detector is not necessary when setting the zero reading.

1. While in normal operation, press and hold the UP/YES button for 5 seconds to enter Calibration Mode. Release the button when the following screen appears.

Calib?
YES/NO

2. If you want to continue with calibration, press and release the UP/YES button. The display will indicate the target gas and **CAL Mode** for a few seconds before showing **FreshAir Adjust?**.

If you want to exit Calibration Mode, press and release the DOWN/NO button. The M2 Rig Monitor will indicate **Leaving CAL Mode** and the M2 Rig Monitor will return to normal operation.

Adjusting the Fresh Air Reading

1. The display will indicate **FreshAir Adjust?** as described above in “Preparing for Calibration”.
2. To continue with adjusting the fresh air reading, press and release the UP/YES button. **ENTER** will alternate with **FreshAir** on the top display line and the current gas reading will be on the bottom display line.

To skip adjusting the fresh air reading, press and release the DOWN/NO button. The display will indicate **SPAN w/Cal Gas?**. Skip to Step 9.

3. Screw the fixed flow regulator into the zero air calibration cylinder.
4. Use the calibration kit sample tubing to connect the fixed flow regulator to the calibration cup/splash guard.
5. Turn the regulator knob counterclockwise to open the regulator.
6. Allow zero air to flow for two minutes.
7. Turn the regulator knob clockwise to close the regulator. The Rig Monitor will continue to display the minimum gas response on the display and retain the response level in its memory.

8. Press and release the ENTER button. The Rig Monitor will perform a fresh air adjustment and the display will indicate **SPAN w/Cal Gas?**
9. If you applied zero air to the detector, unscrew the regulator from the zero air calibration cylinder.
10. If you applied zero air to the detector, leave the sample tubing connected to the regulator and the calibration cup/splash guard.
If you did not apply zero air to the detector, use the calibration kit sample tubing to connect the fixed flow regulator to the calibration cup/splash guard.

NOTE: If the fresh air adjustment fails, see “Troubleshooting” on page 25 for recommended actions.

Adjusting the Span Setting

1. If you want to continue with adjusting the span setting, press and release the UP/YES button. **APPLY** will alternate with **SPAN Gas** on the top display line and the current gas reading will be on the bottom display line.
If you want to skip adjusting the span reading, press and release the DOWN/NO button. The display will indicate **Leaving Cal Mode** and the M2 Rig Monitor will return to normal operation.
2. Screw the calibration gas cylinder onto the fixed flow regulator.
3. Turn the regulator knob counterclockwise to open the regulator.
4. Allow calibration gas to flow for two minutes.
5. Turn the regulator knob clockwise to close it. The Rig Monitor will continue to display the maximum gas response on the display and retain the response level in its memory.
6. Unscrew the calibration gas cylinder from the fixed flow regulator and disconnect the sample tubing from the calibration cup/splash guard hose barb.
7. Adjust the gas reading up or down to match the calibration gas cylinder concentration by using the UP/YES and DOWN/NO buttons, then press and release the ENTER button.
8. The Rig Monitor will perform a span operation. The display will indicate **SPAN Gas PASS** for a few seconds, then indicate **SPAN Gas SAVED** before indicating **Leaving CAL Mode** for a few seconds.

NOTE: If the span adjustment fails, see “Troubleshooting” on page 25 for recommended actions.

9. The display will now alternate between the normal operation screen and the message **REMOVE CAL GAS** for 1 minute. If the calibration gas has not been removed from the detector, remove it now to avoid unwanted alarms.
During this 1 minute period, the signal output will remain fixed at 3.5 mA and the relays will remain in their non-alarm state to avoid unwanted alarms while the calibration gas clears from the detector. At the end of the 1 minute period, the **REMOVE CAL GAS** message will stop appearing and the Rig Monitor will return to normal operation.
10. Store the components of the calibration kit in a safe place.

Adjusting Strobe/Horn Volume

The horn volume on the strobe/horn can be adjusted by doing the following:

1. Disconnect the battery clamps from the + and - terminals of the 12 VDC battery.
2. Loosen the captive screw at the bottom front of the strobe/horn.
3. Grasp the top and bottom of the strobe/horn and push up and out in order to remove the cover.

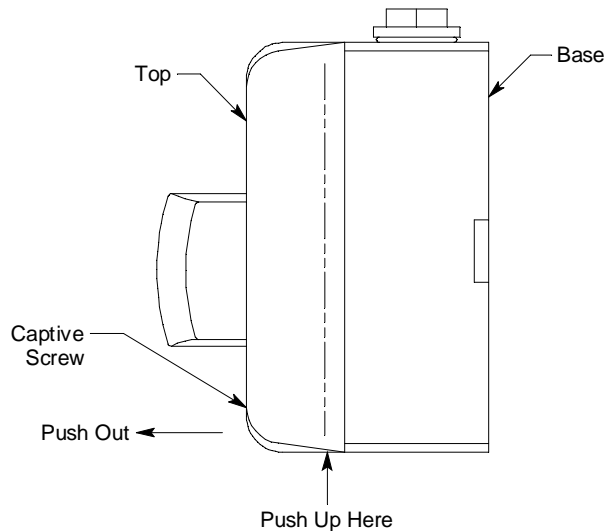

Figure 10: Top Case Removal

4. Turn the cover over and locate the Audio Select switch at the top of the cover as shown in the figure below.

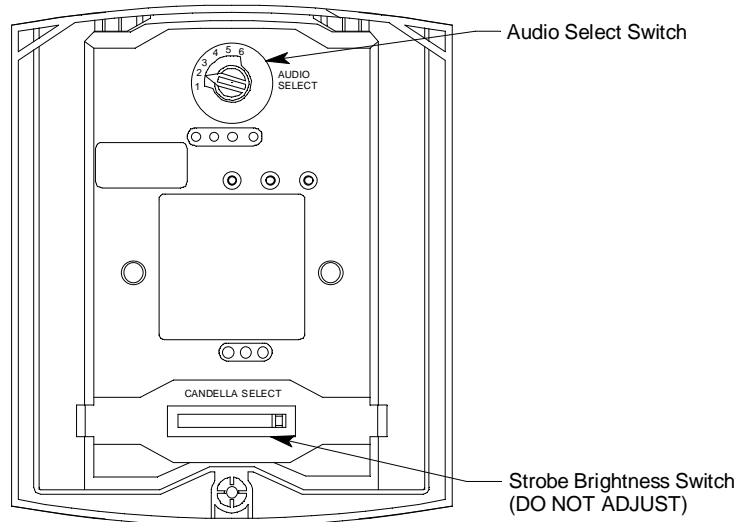

Figure 11: Strobe/Horn Cover

5. The Audio Select switch can be set at any number between 1 and 6. Numbers 1-3 all produce an intermittent buzzing sound with 1 being the loudest and 3 being the quietest. Numbers 4-6 all produce a steady buzzing sound with 4 being the loudest and 6 being the quietest. The factory setting is 2.

6. Turn the Audio Select switch so that the selection arrow is pointing to the desired number.
7. Place the cover over the base and push in and down in order to reinstall the cover. Make sure that the cover is sealed to the base by the gasket.
8. Screw the captive screw at the bottom front of the strobe/horn back in.

Replacing Components of the M2 Rig Monitor

Replacing the H₂S Plug-in Sensor

1. Disconnect the battery clamps from the + and - terminals of the 12 VDC battery.
2. Unscrew the calibration cup/splash guard from the detector housing cap.
3. Unscrew the detector cap from the housing body. Make sure not to lose the cap gasket. See Figure 3 for an illustration of the H₂S detector.
4. Unplug and remove the sensor.
5. Carefully match the replacement sensor's male pins with the 4-socket pattern in the top section and plug it in.
6. Make sure the cap gasket is in place and screw the detector cap back onto the housing body.
7. Screw the calibration cup/splash guard back onto the detector housing cap.
8. Connect the battery clamps to the + and - terminals of the 12 VDC battery.

CAUTION: Allow the replacement sensor to warm up for 15 minutes before you continue with the next step.

9. Calibrate the detector as described in "Calibration" on page 27.

Replacing the Gas Detector

NOTE: In most cases, it is only necessary to replace the H₂S sensor.

1. Disconnect the battery clamps from the + and - terminals of the 12 VDC battery.
2. Remove the H₂S detector junction box cover.
3. Disconnect the detector leads from the terminal block in the junction box. Note the position of the color-coded leads as you remove them.
4. Unscrew the calibration cup/splash guard from the detector housing cap.
5. Unscrew the detector from the junction box hub.
6. Guide the detector leads of the replacement detector through the junction box hub then screw the mounting threads of the detector into the hub.
7. Connect the detector leads to the terminal block the same way the old detector was wired. See Figure 8 to verify the connections are correct.
8. Screw the calibration cup/splash guard onto the new detector's housing cap.
9. Reinstall the junction box cover.
10. Connect the battery clamps to the + and - terminals of the 12 VDC battery.

CAUTION: *Allow the replacement detector to warm up for 5 minutes before you continue with the next step.*

11. Calibrate the replacement detector as described in the Calibration section of this manual.

Chapter 7: RS-485 Modbus Output

Overview

This chapter describes the M2 Rig Monitor's RS-485 Modbus output and how to configure the Rig Monitor to make use of it. It also discusses how to wire the Rig Monitor into a Modbus system.

The Rig Monitor provides an RS-485 serial communications interface. It is a Modbus Slave Device, supporting 2-wire RS-485 Modbus RTU serial communications.

Wiring the M2 Rig Monitor in a Modbus System

The Rig Monitor is a 2-wire Modbus RTU device. When wiring the Rig Monitor into a Modbus system, adhere to standard Modbus wiring practices per the Modbus Over Serial Line Specification and Implementation Guide V1.0 or later. This document can be found online at www.modbus.org/specs.php.

The Modbus protocol supports a maximum of 247 unique slave addresses (1-247). The M2 Rig Monitor's line driver provides for up to 128 M2 Rig Monitors to be connected together without the need for a repeater. Figure 13 & Figure 14 below illustrate typical Rig Monitor wiring configurations. If more than 128 M2 Rig Monitors need to be connected together, RS-485 repeater(s) should be used such that no more than 128 M2 Rig Monitors reside on any given network segment.

CAUTION: *The network segment can only support 128 units if RKI M2 Rig Monitors are being used. The use of any other instruments will lower the number of units that may reside on any given network segment.*

NOTE: Only M2 Rig Monitors produced after November 2010 have the capability to support a 128-unit segment. M2 Rig Monitors produced before November 2010 can only support a 32-unit segment.

The MODBUS terminal strip is located on the terminal PCB (see Figure 4). The following signals are available at the Modbus terminal strip:

Table 6: Modbus Terminal Strip Signals

Modbus Terminal Label (RS-485 Name)	Modbus Signal Name
A	D0
B	D1
C	Common

Recommended Modbus Wiring

The recommended Modbus wiring for the Rig Monitor is illustrated in Figure 12 below. In this configuration, 5 wires are used for wiring the Rig Monitor into a Modbus system. Figure 12 also illustrates typical alarm device wiring.

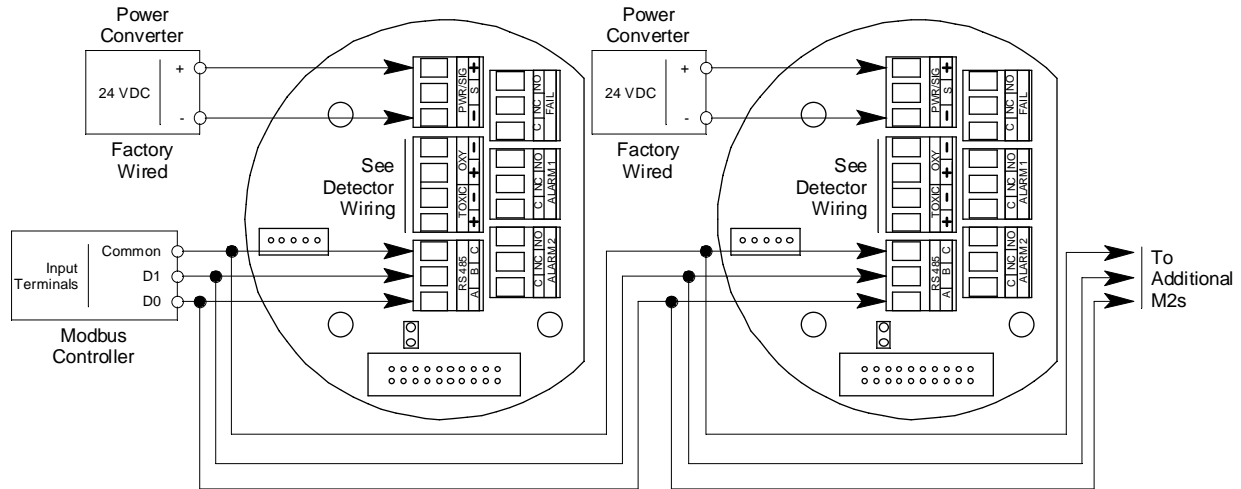

Figure 12: Recommended Modbus Wiring

Termination Jumper

The Rig Monitor includes a 2-pin termination header (see Figure 4) that is used when the Rig Monitor is used in a Modbus system. Every Rig Monitor is supplied with a termination jumper (a jumper block) installed onto this header. If the Rig Monitor is not used in a Modbus system, this jumper has no function. When the Rig Monitor is installed in a Modbus system, this jumper must be installed in a Rig Monitor that is at the end of a Modbus line. Any Rig Monitor in a Modbus system that is not at the end of a line must have the termination jumper removed (see Figure 13 & Figure 14 below).

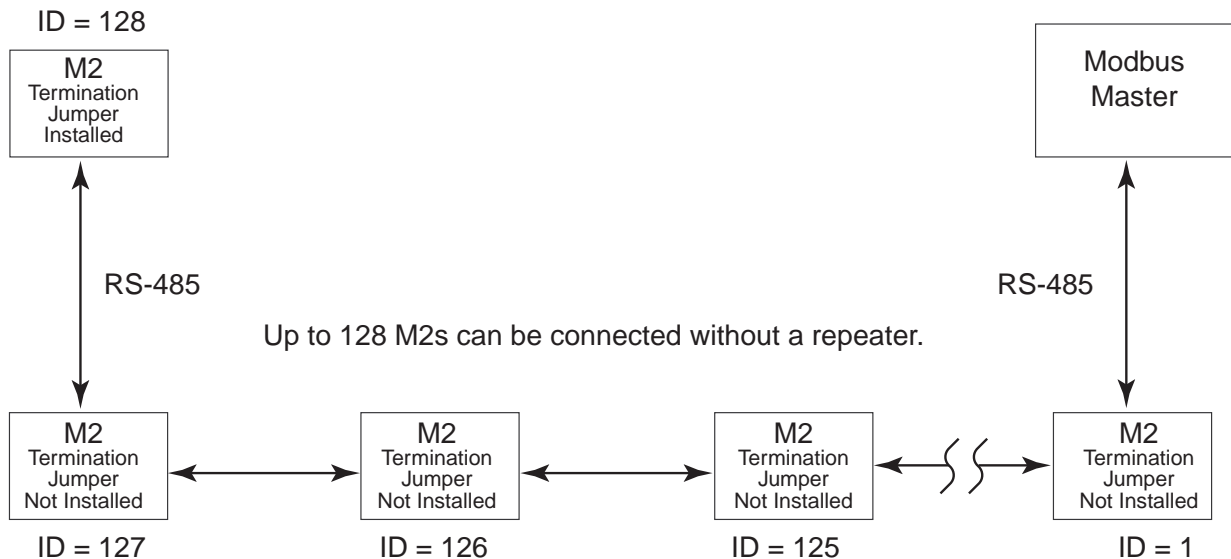
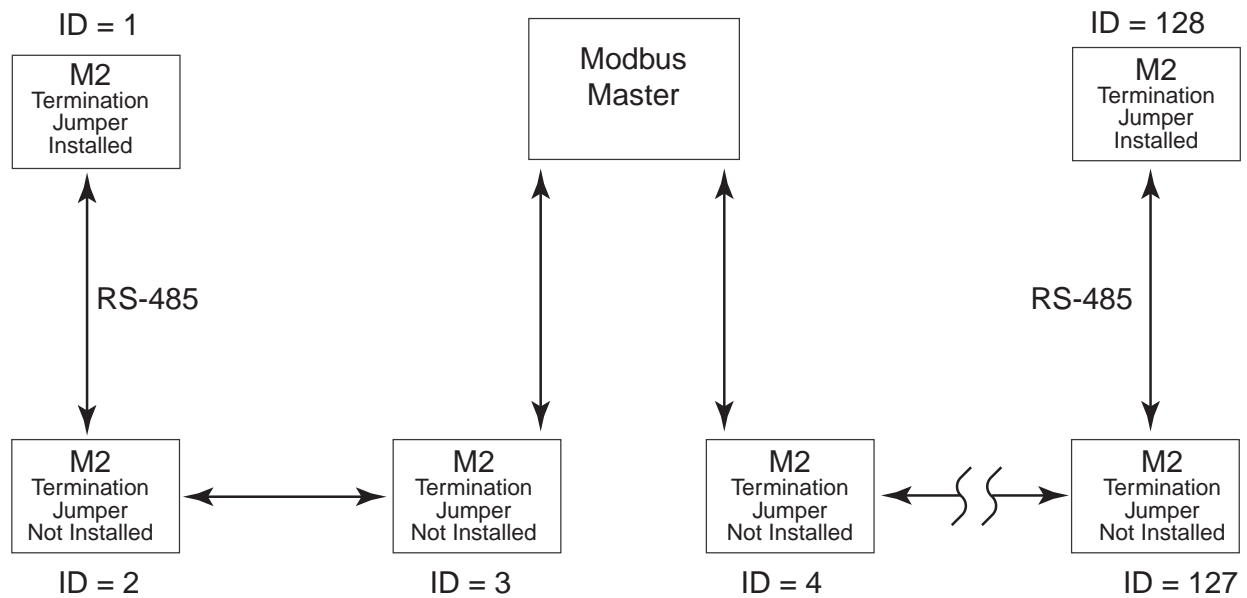

Figure 13: Multiple M2 Rig Monitors in a Daisy Chain Configuration



Up to 128 M2s can be connected without a repeater.

Figure 14: Multiple M2 Rig Monitors in a Two Branch Configuration

Using the M2 Rig Monitor in a 4-wire Modbus System

Although the Rig Monitor is a 2-wire Modbus RTU device, it can be used with a 4-wire Modbus controller if the system wiring is modified as follows:

- Connect the controller's TxD0 and RxD0 wires together and use this connection as the 2-wire Modbus D0 signal.
- Connect the controller's TxD1 and RxD1 wires together and use this connection as the 2-wire Modbus D1 signal.
- Connect these D0 and D1 signals and the common wire from the controller to the 2-wire Modbus Network of Rig Monitors.

Modbus Mode

Modbus Mode allows you to configure various parameters relating to the Modbus setup of the Rig Monitor. Modbus Mode includes a 5-minute time-out feature. If you do not press a control button for 5 minutes, the Rig Monitor automatically returns to normal operation.

NOTE: If the M2 Rig Monitor returns to normal operation because of a time-out, it enters a warm-up period just as it does when it is first turned on.

1. While in normal operation, simultaneously press and hold the DOWN/NO and ENTER buttons for 5 seconds to enter Modbus Mode. Release the buttons when the

following screen appears.



2. To exit Modbus Mode, press and release the DOWN/NO button. The M2 Rig Monitor will return to normal operation.

To continue in Modbus Mode, press and release the UP/YES button. The current ENABLED/DISABLED setting will appear.

3. If you want to change the currently displayed parameter, use the UP/YES and DOWN/NO buttons to adjust it to the desired setting, then press ENTER to continue to the next parameter.

If the currently displayed parameter setting is OK, press the ENTER button to proceed to the next parameter.

Table 7 lists the Rig Monitor Modbus Mode parameters you can set. Table 7 also lists the factory set value for each parameter.

Table 7: Configuration Parameters

Modbus Mode Parameter	Available Settings & Description
Enabled/Disabled	Can be set to ENABLED or DISABLED (factory setting). Enables or disables the Modbus output.
Slave ID	The Slave ID can be set to values from 1 (factory setting) to 247. The Rig Monitor will only receive messages from the Master which are addressed to this Slave ID (except for broadcast messages which are received by all slaves).
Baud Rate	Can be set to 1200, 2400, 4800, 9600 (factory setting), 14440, & 19200.
Parity	EVEN (factory setting), ODD, NONE
Response Delay	The response delay can be set from 0 (factory setting) to 20 mS. This is an optional additional delay inserted by the Rig Monitor prior to returning a response message to the Master. It may be helpful in some installations where the Master's preparedness to receive responses might be delayed.

4. When you have scrolled through all the adjustable parameters, **SAVE IT? YES/NO** appears on the display.
5. If you do not wish to save the adjustments, press and release the DOWN/NO button. The **DO OVER? YES/NO** message will display. Press and release the DOWN/NO button. The **ABORT? YES/NO** message will display. Press the UP/YES button to return to normal operation.

If you wish to change some of the adjustments made, press and release the DOWN/NO button. The **DO OVER? YES/NO** message will display. Press and release the UP/YES button. The **Re-do MB Setup** message will display and the M2 Rig Monitor will

return to the first adjustable parameter. Go back to step 3 and continue.

If you want to save the adjustments made, press and release the UP/YES button. **Modbus Saved** is indicated on the display for a few seconds and the M2 Rig Monitor returns to normal operation.

NOTE: All M2 Rig Monitors on a Modbus network must be configured with the same baud rate and parity, and each M2 Rig Monitor must have a unique slave ID. For an M2 Rig Monitor to participate on a network, the ENABLED/DISABLED setting must be set to ENABLE.

Supported Modbus Functions

The Rig Monitor supports Function Code 03: Read Holding Registers and Function Code 16: Write Registers. The register assignments detailed below were implemented in Rig Monitor firmware version 5.0. Please see revision B of the M2 manual if you have an M2 Rig Monitor with a firmware version previous to 5.0.

WARNING: *Do not attempt to use registers according to the instructions below with units that have firmware versions previous to 5.0. For the Modbus register assignments of M2 Rig Monitors with firmware previous to 5.0, see revision B of the M2 Operator's Manual. The firmware version is shown on the Information Screen described on page 17.*

Function Code 03: Read Holding Registers

There are a total of 40 registers available to be read via this Function Code.

Registers 1 - 2

The format (bit & field assignments) for registers 1 - 2 is shown below in Table 8 - Table 9.

Table 8: Register 1, Numerical Reading with Sign & Decimal Point Bit & Field Assignments

Bit(s)	Value & Field
[15]	<u>Sign of Reading</u> 0 = Positive 1 = Negative
[14:13]	<u>Format of Reading</u> 0 = XXX (no decimal point) 1 = XX.X 2 = X.XX 3 = .XXX
[12:0]	Numerical value of display reading (8000 max)

Table 9: Register 2, Operating State, Alarms & Relays Bit & Field Assignments

Bit(s)	Value
[15:12]	<u>Operating State</u> 0 = Undefined 1 = Initialization 2 = Normal 3 = Warm-up 4 = Fail 5 = Calibration 6 = Post-Calibration 7 = Low Power 8 = Setup
[11]	<u>Gas Type Change</u> 0=Not Changed 1=Changed
[10]	<u>Configuration Change</u> 0=Not Changed 1=Changed
[9]	<u>Calibration Activity Flag</u> 0=No Calibration Activity 1=Calibration Activity Has Occurred
[8]	<u>Fail Status</u> 0 = Fail Not Asserted 1 = Fail Asserted
[7:6]	<u>Alarm 2 Status</u> 0 = No Alarm 1 = Unacknowledged Alarm 2 = Acknowledged Alarm 3 = Unused Code
[5:4]	<u>Alarm 1 Status</u> 0 = No Alarm 1 = Unacknowledged Alarm 2 = Acknowledged Alarm 3 = Unused Code
[3]	<u>Overscale Status</u> 0 = Not Overscale 1 = Overscale
[2]	<u>Fail Relay Status</u> 0 = Not Energized 1 = Energized
[1]	<u>Alarm 2 Relay Status</u> 0 = Not Energized 1 = Energized

Table 9: Register 2, Operating State, Alarms & Relays Bit & Field Assignments (Continued)

Bit(s)	Value
[0]	<u>Alarm 1 Relay Status</u> 0 = Not Energized 1 = Energized

Register 3

Register 3 is the supply voltage (0.1 volt per count).

Registers 4 - 11

The 16 bytes in these registers contain the same ASCII text information that is displayed on the Rig Monitor's LCD (not NULL Terminated).

Register 12

Register 12 is the range (full scale readout).

Register 13

Register 13 is the alarm 1 set point.

The decimal point location is the same as specified in Register 1.

Register 14

Register 14 is the alarm 2 set point.

The decimal point location is the same as specified in Register 1.

Registers 15 - 19

Registers 15 - 19 are the Gas Name ASCII String (NULL Terminated).

Registers 20 - 22

Registers 20 - 22 are the Gas Units String (NULL Terminated).

Register 23

Register 23 is the alarm 1 trigger.

0=Decreasing

1=Increasing

Register 24

Register 24 is the alarm 1 normal relay state.

0=Normally De-Energized

1=Normally Energized

Register 25

Register 25 is the alarm 1 relay reset.

0=Latching

1=Self-Resetting

Register 26

Register 26 is the alarm 1 ON delay.

Integer values are in seconds.

Register 27

Register 27 is the alarm 1 OFF delay.
Integer values are in seconds.

Register 28

Register 28 is the alarm 2 trigger.
0=Decreasing
1=Increasing

Register 29

Register 29 is the alarm 2 normal relay state.
0=Normally De-Energized
1=Normally Energized

Register 30

Register 30 is the alarm 2 relay reset.
0=Latching
1=Self-Resetting

Register 31

Register 31 is the alarm 2 ON delay.
Integer values are in seconds.

Register 32

Register 32 is the alarm 2 OFF delay.
Integer values are in seconds.

Register 33

Register 33 is zero suppression.
Toxics and LEL: 0%-6% of full scale
Oxygen: 0%-0.7% Oxygen
The decimal point location is the same as specified in Register 1.

Register 34

Register 34 is noise filter.
Integer values in seconds.
0-60 in 5 second increments.

Register 35

Register 35 is calibration timeout in minutes (5, 10, 15, 20, 25, or 30).

Register 36

Register 36 is calibration month (upper byte) and day (lower byte).
This is zero based (e.g. January=0 and the 1st=0).

Register 37

Register 37 is the calibration year.

Register 38

Register 38 is the calibration outcome.

Upper=Gas Operation

Lower=Air Operation

Calibration Outcome Codes:

- 1=Sensor Missing
- 2=Sensor Too Weak
- 3=Signal Too Strong
- 4=Not Enough Span
- 5=Negative Reading
- 6=Span Gas Value Is Not OK
- 7=Calculated Zero Is Too Low
- 8=Calculated Zero Is Too High
- 9=Zero Failure
- 10=Span Failure
- 11=Calibration Is Overscale
- 12=LEL Sensor Offset Is Too High
- 13=LEL Null Operation Failed
- 14=Operation Not Performed

Register 39

Register 39 is the auto-zero disable.

0=AutoZero Enabled

1=AutoZero Disabled

Register 40

Register 40 is the remote configuration register access level

0=None

1=Alarm Reset Only

2=All

Function Code 16: Write Registers

There are 21 registers in Function Code 16 that can be used to write to the Rig Monitor. This manual only describes Register 16 because it can be used to reset an alarm condition. For a complete description of Function Code 16, request Appendix B from RKI Instruments, Inc.

Register 16

Register 16 performs the same functions as the buttons on the Rig Monitor. Among other things, it is useful for remotely silencing alarms. With the Rig Monitor in an alarm condition, bit [0] can be used to silence it.

Table 10: Register 16, Button Function

NOTE: Register 40, the remote configuration register, must be set to 1 or 2 in order for Register 16 to work.

Bit	Value & Field
[0]	ENTER (also used for "Alarm Reset") 0=Not Pressed 1=Pressed
[1]	DOWN/NO 0=Not Pressed 1=Pressed
[2]	UP/YES 0=Not Pressed 1=Pressed
[3]	<u>HOLD Status</u> 0=Button(s) Pressed and Released 1=Button(s) Pressed and Held

Parts List

Table 11 lists replacement parts and accessories for the M2 Rig Monitor Transmitter.

Table 11: Parts List

Part Number	Description
06-1248RK	Calibration kit sample tubing (3/16 in. x 5/16 in.; specify length when ordering)
07-0033RK	Cap gasket, for CSA type CO and H ₂ S detector
18-0400RK-01	H ₂ S detector junction box with rubber spacers
18-0405RK-03	M2 junction box w/o cover
18-0409RK	M2 junction box cover, with lens
45-6132RK	Termination jumper
51-0096RK	Strobe/horn, 10-33 VDC, NEMA 4X
65-2423RK-05	H ₂ S detector assembly, CSA version
65-2427RK-05	H ₂ S detector with j-box (does not include cable or cable bushing)
71-0234RK	<i>M2 Rig Monitor Operator's Manual (this document)</i>
81-0076RK-03	Zero air calibration cylinder, 103 liter steel
81-0151RK-02	Calibration cylinder, H ₂ S, 25 ppm in nitrogen, 58 liter aluminum
81-0151RK-04	Calibration cylinder, H ₂ S, 25 ppm in nitrogen, 34 liter aluminum
81-1051RK	Regulator, with gauge and knob, 0.5 liter/minute continuous flow
81-1116RK	Calibration cup/splash guard
ES-1537-H2S	H ₂ S sensor, plug-in

Appendix A: Control Button Quick Reference Guide

The M2 Rig Monitor’s control buttons allow access to operational modes, resetting of alarms, and display of the Information Screen. Table 12 shows which button combinations perform these functions and which parameters are available for adjustment while in the operational modes. While in these modes, display prompts showing a “?” require you to respond by pressing either the UP/YES (for yes) or DOWN/NO (for no) button. To change parameter settings, use the UP/YES and DOWN/NO buttons to get the desired setting, then press and release the ENTER button to accept the setting.

Table 12: Control Button Quick Reference Chart

Mode Entered or Function Performed	Button Combination	Adjustable or Viewable Parameters
Alarm Reset	Press and Release ENTER	n/a
Show Information Screen	Press and Hold DOWN/NO	<ul style="list-style-type: none"> • Input Voltage • M2 Rig Monitor Version/Revision Information
Calibration Mode	Press and Hold UP/YES for 5 seconds	<ul style="list-style-type: none"> • Fresh Air Adjust • Span (or Zero for Oxygen) Adjust with Calibration Gas
Configuration Mode	Press and Hold UP/YES & ENTER for 5 seconds	<ul style="list-style-type: none"> • Alarm Levels • Increasing or Decreasing Alarms • Normally Energized or Normally De-energized Relays • Latching or Self-resetting Alarms • Alarm On Delay • Alarm Off Delay (if self-resetting) • Zero Suppression • Noise Filter • Calibration Time-out Period
Gas Type Mode	Press and Hold UP/YES and DOWN/NO for 5 seconds	Gas Type
Modbus Mode	Press and Hold DOWN/NO and ENTER for 5 seconds	<ul style="list-style-type: none"> • Enable or Disable Modbus • Slave ID • Baud Rate • Parity • Response Delay

Appendix B: Function Code 16 Registers

The M2 Rig Monitor supports Function Code 16 that allows writing to the Rig Monitor. There are 21 registers in this Function Code. The register assignments detailed below were implemented in M2 Rig Monitor firmware version 5.0. Please see revision B of the M2 manual if you have an M2 Rig Monitor with a firmware version previous to 5.0.

WARNING: *Do not attempt to use registers according to the instructions below with units that have firmware versions previous to 5.0. For the Modbus register assignments of M2 Rig Monitors with firmware previous to 5.0, see revision B of the M2 Operator's Manual. The firmware version is shown on the Information Screen described on page 17.*

Register 1

Register 1 is the alarm 1 set point.
Value must be an integer. Any decimals are omitted.

Register 2

Register 2 is the alarm 1 trigger.
0=Decreasing
1=Increasing

Register 3

Register 3 is the alarm 1 relay state.
0=Normally De-Energized
1=Normally Energized

Register 4

Register 4 is the alarm 1 relay reset.
0=Latching
1=Self-Resetting

Register 5

Register 5 is the alarm 1 ON delay.
Integer value is in seconds.

Register 6

Register 6 is the alarm 1 OFF delay.
Integer value is in seconds.

Register 7

Register 7 is the alarm 2 set point.
Value must be an integer. Any decimals are omitted.
The decimal point location is the same as specified in Register 1 of Function Code 03.

Register 8

Register 8 is the alarm 2 trigger.
0=Decreasing
1=Increasing

Register 9

Register 9 is the alarm 2 relay state.
0=Normally De-Energized
1=Normally Energized

Register 10

Register 10 is the alarm 2 relay reset.
0=Latching
1=Self-Resetting

Register 11

Register 11 is the alarm 2 ON delay.
Integer value is in seconds.

Register 12

Register 12 is the alarm 2 OFF delay.
Integer value is in seconds.

Register 13

Register 13 is the zero suppression.
Toxics and LEL: 0%-6% Full Scale
Oxygen: 0%-0.7% Oxygen
Value must be an integer. Any decimals are omitted.

Register 14

Register 14 is the noise filter.
Integer value is in seconds (0-60 in 5 second increments).

Register 15

Register 15 is the calibration timeout.
Value is in minutes (5, 10, 15, 20, 25, or 30).

Register 16

Register 16 is explained in “Supported Modbus Functions” in the M2 Rig Monitor manual.

Register 17

Register 17 is the calibration month (MSB) and day (LSB).
This is zero-based (e.g. January=0 and the 1st=0).

Register 18

Register 18 is the calibration year.

Register 19

Register 19 is for clearing change flags. When parameters are changed at the M2 Rig Monitor, a flag is raised at the controller. This register can be used to clear those flags.

Table 13: Register 19, Clear Change Flags

Bit(s)	Value & Field
[15:2]	Unused
[1]	Write "1" to this bit to clear "Gas Type Changed" flag
[0]	Write "1" to this bit to clear "Configuration Changed" flag

Register 20

Register 20 is the AutoZero Disable.

0=AutoZero Enabled

1=AutoZero Disabled