

Combustible Gas and Hydrogen Sulfide Beacon 200 Rig Monitor Operator's Manual

Part Number: 71-0243RK

Revision: 0

Released: 2/20/12

WARNING

Read and understand this instruction manual before operating instrument. Improper use of the rig monitor could result in bodily harm or death.

Periodic calibration and maintenance of the rig monitor is essential for proper operation and correct readings. Please calibrate and maintain this rig monitor regularly! Frequency of calibration depends upon the type of use you have and the sensor types. Typical calibration frequencies for most applications are between 3 and 6 months, but can be required more often or less often based on your usage.

Product Warranty

RKI Instruments, Inc. warrants gas alarm equipment sold by us to be free from defects in materials, workmanship, and performance for a period of one year from date of shipment from RKI Instruments, Inc. Any parts found defective within that period will be repaired or replaced, at our option, free of charge. This warranty does not apply to those items, which by their nature, are subject to deterioration or consumption in normal service, and which must be cleaned, repaired, or replaced on a routine basis. Examples of such items are as follows:

- a) Absorbent cartridges
- b) Pump diaphragms and valves
- c) Fuses
- d) Batteries
- e) Filter elements

Warranty is voided by abuse including mechanical damage, alteration, rough handling, or repair procedures not in accordance with the operator's manual. This warranty indicates the full extent of our liability, and we are not responsible for removal or replacement costs, local repair costs, transportation costs, or contingent expenses incurred without our prior approval.

THIS WARRANTY IS EXPRESSLY IN LIEU OF ANY AND ALL OTHER WARRANTIES AND REPRESENTATIONS, EXPRESSED OR IMPLIED, AND ALL OTHER OBLIGATIONS OR LIABILITIES ON THE PART OF RKI INSTRUMENTS, INC. INCLUDING BUT NOT LIMITED TO, THE WARRANTY OF MERCHANTABILITY OR FITNESS FOR A PARTICULAR PURPOSE. IN NO EVENT SHALL RKI INSTRUMENTS, INC. BE LIABLE FOR INDIRECT, INCIDENTAL, OR CONSEQUENTIAL LOSS OR DAMAGE OF ANY KIND CONNECTED WITH THE USE OF ITS PRODUCTS OR FAILURE OF ITS PRODUCTS TO FUNCTION OR OPERATE PROPERLY.

This warranty covers instruments and parts sold to users by authorized distributors, dealers, and representatives as appointed by RKI Instruments, Inc.

We do not assume indemnification for any accident or damage caused by the operation of this gas monitor, and our warranty is limited to the replacement of parts or our complete goods.

Table of Contents

Chapter 1: Introduction	1
Overview	1
About the Beacon 200 Gas Monitor	1
About this Manual	2
Specifications	3
Chapter 2: Description	4
Overview	4
External Description	5
Internal Description	9
Chapter 3: Installation and Start Up	14
Overview	14
Mounting the Beacon 200 Rig Monitor	14
Wiring the Beacon 200 Rig Monitor	17
Starting Up the Beacon 200 Rig Monitor	20
Chapter 4: Operation	21
Overview	21
Normal Operation	21
Recorder Output Operation	22
Alarm Indications	23
Viewing & Resetting Min/Max Readings	27
Chapter 5: Channel Control and Setup Program	28
Overview	28
Enable/Disable Channel(s) Menu	29
Configure Channel Settings Menu	30
View System Information Menu	32

Chapter 6: Maintenance	33
Overview	33
Calibration Program	33
Adjusting Strobe/Horn Volume	39
Replacing Components of the Rig Monitor	41
Preventive Maintenance	44
Troubleshooting	46
Parts List	48

Chapter 1: Introduction

Overview

This chapter briefly describes the Beacon 200 Rig Monitor. This chapter also describes the *Beacon 200 Rig Monitor Operator's Manual* (this document). Table 1 at the end of this chapter lists the specifications for the Beacon 200 Rig Monitor.

About the Beacon 200 Rig Monitor

The Beacon 200 Rig Monitor is a fixed-mounted, continuous-monitoring gas detection instrument. This gas monitor is capable of detecting gas at two locations. The display screen simultaneously displays the gas readings.

The Rig Monitor displays the current gas readings on an LCD display which is visible through the window in the cover (front face) and provides a 4 - 20 mA signal which indicates the target gas reading for use by a recording device or programmable controller. Three sets of relay contacts, two controlled by the gas alarms and one by the fail alarm, rated at 115 VAC 10 amps are available for controlling devices such as lights or horns or for controlling higher rated relays. The alarm 1 relay is factory wired to the strobe/horn and is not available for field use.

Two instrument programs allow you to display and change channel and calibration settings. They are the Channel Control & Setup Program and the Calibration Program.

About this Manual

The *Beacon 200 Gas Monitor Operator's Manual* uses the following conventions for notes, cautions, and warnings.

NOTE: Describes additional or critical information.

CAUTION: *Describes potential damage to equipment.*

WARNING: *Describes potential danger that can result in injury or death.*



Caution: refer to accompanying documentation

~ Vac (AC voltage)

=== Vdc (DC voltage)

Specifications

Table 1 lists specifications for the Beacon 200 Rig Monitor.

Table 1: Beacon 200 Rig Monitor Specifications

Description	Specification
Input Power	10.8 - 14.5 VDC, 1.2A VDC
Construction (housing)	Fiberglass/polyester with lexan window (NEMA 4X)
Controller Dimensions	21.0 in. H x 8.5 in. W x 7.00 in. D (533 mm H x 216 mm W x 178 mm D)
Weight	20 lbs.
Environmental Conditions	<ul style="list-style-type: none">-20°C to 50°C (-4°F to 122°F) max. ambientMaximum humidity of 80% relative
Relays	<ul style="list-style-type: none">Relay contacts rated for 10A @ 115/220V~ resistive or 10A @ 30V --- resistiveSPDT Form C
User Controls	<ul style="list-style-type: none">Reset switchProgram buttons: ESCAPE, UP/YES, DOWN/NO, and ENTER
Detection Range	Channel 1: 0 to 100% LEL combustible gas, methane calibration standard Channel 2: 0 to 100 PPM (parts per million) H ₂ S
Response Time	90% in 30 seconds
Accuracy	LEL: ± 5% of reading or ± 2 % LEL (whichever is greater) H₂S: ± 5% of reading or ± 2 ppm H ₂ S (whichever is greater)

WARNING: When using the Beacon 200 Rig Monitor, you must follow the instructions and warnings in this manual to assure proper and safe operation of the Beacon 200 Rig Monitor and to minimize the risk of personal injury. Be sure to maintain and periodically calibrate the Beacon 200 Rig Monitor as described in this manual.

Chapter 2: Description

Overview

This chapter describes external and internal components of the Beacon 200 Rig Monitor.

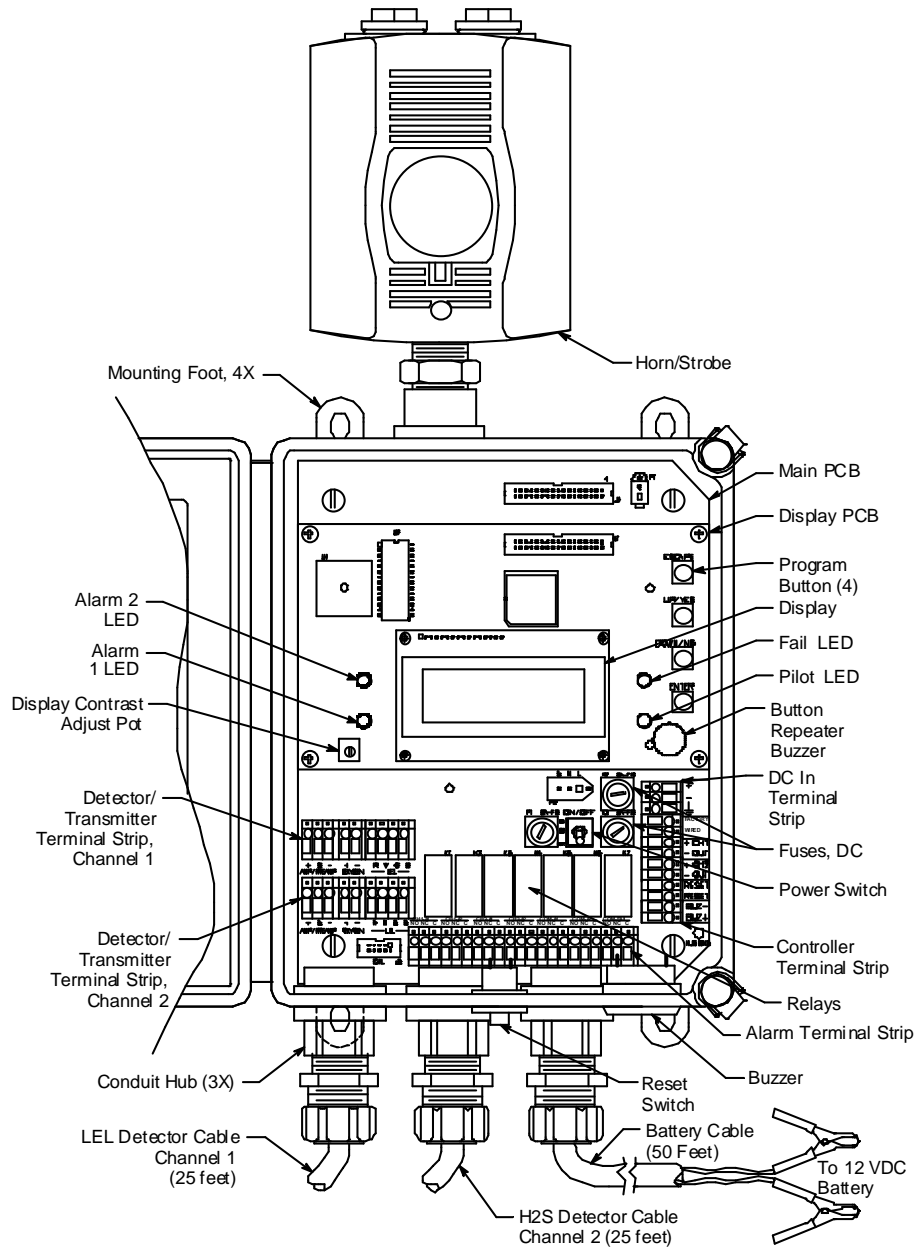

Figure 1. Beacon 200 Rig Monitor Component Location

External Description

This section describes the housing and all external components of the Beacon 200 Rig Monitor. For the purposes of this description, the housing door is considered the front of the monitor.

Housing

The Rig Monitor's fiberglass housing is weather- and corrosion-resistant. It is suitable for installation where general purpose equipment is in use. The housing door is hinged on the left side and is secured by two latches on the right side. The display screen and status lights are visible through windows in the housing door. Four mounting feet are attached to the back of the housing (one at each corner). The mounting feet allow you to install the housing to a vertical surface. Three conduit hubs on the bottom of the housing are for external wiring connections.

CAUTION: *To avoid electrical interference, do not route detector head and power wiring through the same conduit hub.*

Reset Switch

The reset switch is on the bottom of the housing. It is in front of the conduit hubs. The reset switch serves three functions:

- Resets the alarm circuits for “latched” alarms after an alarm 1 or alarm 2 condition passes.

You can set each channel for latched or self-resetting alarms in the Channel Control & Setup Program.

- Silences the buzzer during an alarm 1 or alarm 2 condition. You cannot silence failure alarms.
- Displays and resets the minimum and maximum gas concentration values.

Buzzer

The buzzer is on the bottom of the housing. It is on the far right. The buzzer sounds audible alarms to warn you of gas alarms and instrument failures.

LEL Detector Junction Box and Cable

The LEL detector consists of a junction box with a mounting bracket, the detector, and the calibration cup/splash guard.

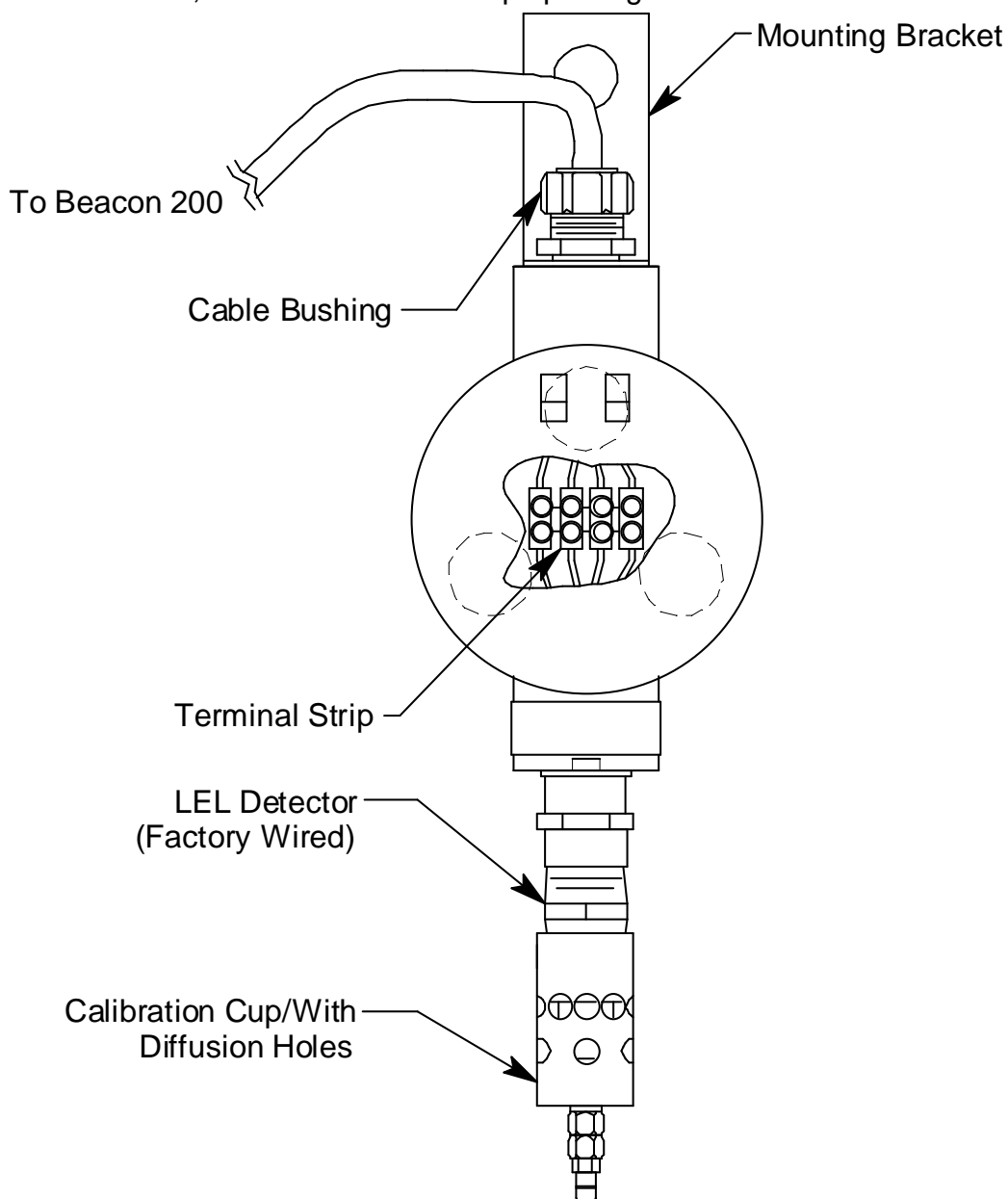

Figure 2. LEL Junction Box Component Location

The LEL detector is factory wired through the left cable bushing of the Beacon 200 and has a 25 foot cable for remote installation. The mounting bracket at the top of the junction box is used to mount the junction box. The junction box protects the detector wiring connections. Three spacers installed on the back of the junction box control the distance of the junction box from a mounting surface and ensure that there is enough room to perform a calibration. A cover on the front of the junction box allows access

to the interior of the junction box.

The combustible gas detector is a catalytic type detector that produces an electrical output that corresponds to the detection range. It is packaged in a 1/2 inch NPT nipple with a sintered metal flame arrestor on one end allowing ambient air to diffuse into the detector. The flame arrestor also contains any sparks which may occur within the detector. The calibration cup/splash guard is screwed onto the bottom of the detector.

H₂S Detector Junction Box and Cable

The H₂S detector consists of a junction box with a mounting bracket, the detector, and the calibration cup/splash guard.

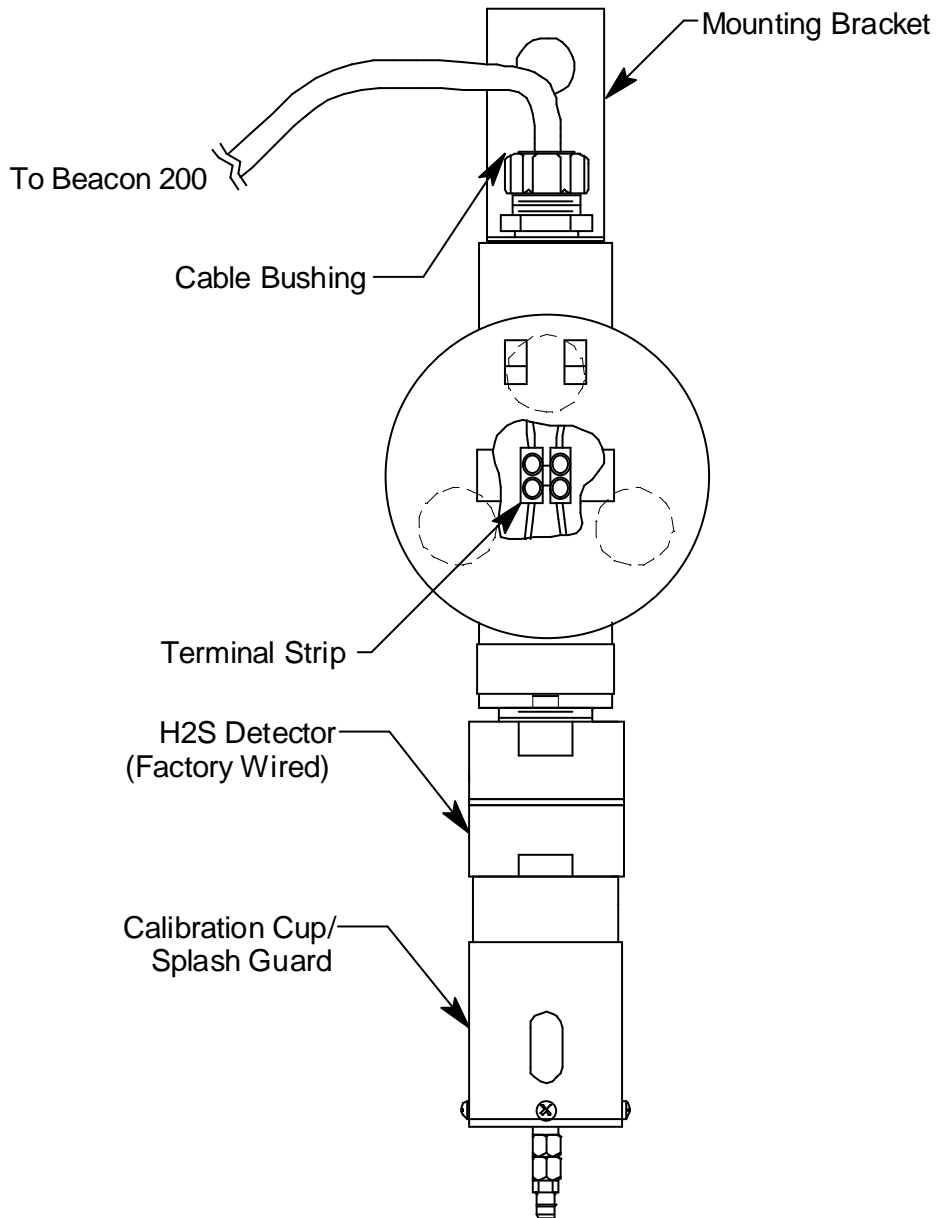

Figure 3. H₂S Junction Box Component Location

The H₂S detector is factory wired through the middle cable bushing of the Beacon 200 and has a 25 foot cable for remote installation. The mounting bracket at the top of each junction box is used to mount the junction box. The junction box protects the detector wiring connections. Three spacers installed on the back of the junction box control the distance of the junction box from a mounting surface and ensure that there is enough room to perform a calibration. A cover on the front of the junction box allows access to the interior of the junction box.

The detector housing body protects the sensing components within the housing body. Use the removable cap near the bottom of the housing body to access the sensor for maintenance or replacement. The cap protects the sensor from damage and includes a flame arrestor which contains any sparks which may occur within the detector housing body. A cap gasket seals the interface between the housing body and cap. A flame arrestor guard is permanently bonded to the cap.

The calibration cup/splash guard is screwed onto the bottom of the flame arrestor guard.

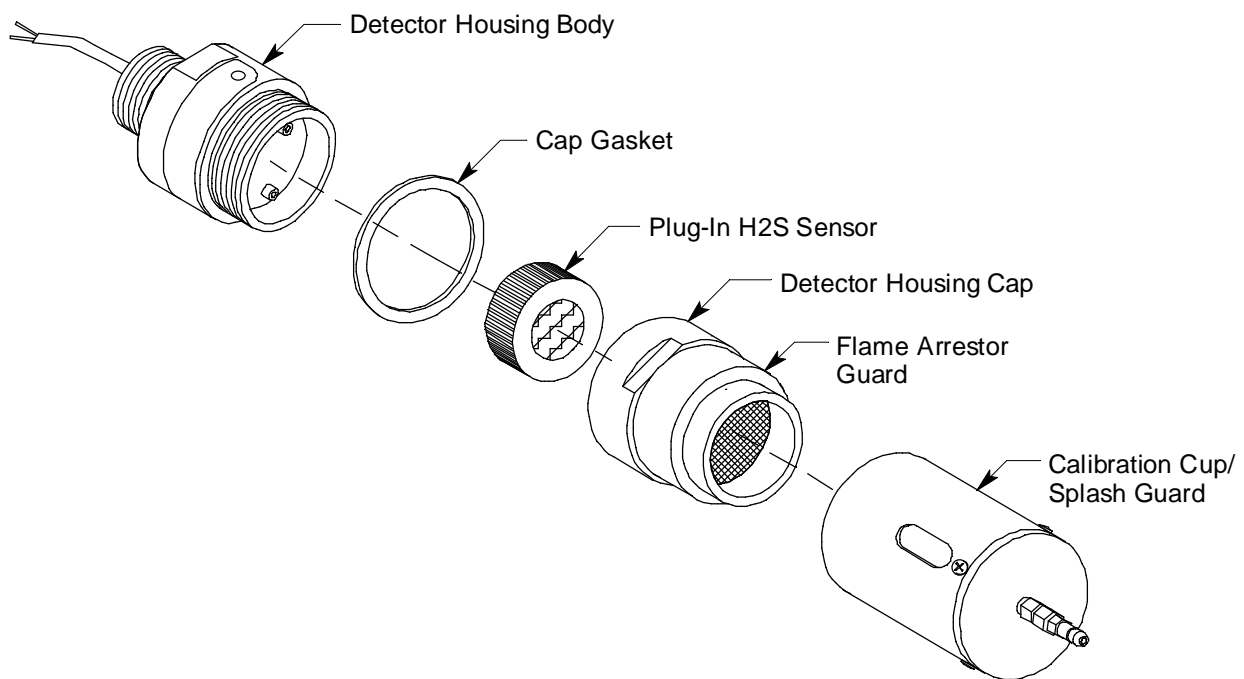

Figure 4. H₂S Detector Component Location

The sensor is secured within the sensor housing by four pins. Through a series of chemical and electrical reactions, the sensor produces an electrical output that corresponds to the detection range of the detector. A pre-amplifier, located between the sockets and two interconnect wires, conditions the sensor's signal before the signal reaches the controller.

12 VDC Battery Cable

A 50 foot cable with clamps for connection to a 12 VDC battery (customer supplied battery not included) is factory-wired through the right cable bushing of the Beacon 200. One end of the cable is connected to the DC In terminal strip.

Internal Description

This section describes the internal components of the Rig Monitor.

Display Printed Circuit Board (PCB)

The display PCB is mounted to the power supply mounting plate which is in turn mounted to the main PCB. The power supply mounting plate and main PCB are described below. The display PCB includes the display, the status lights, and the program buttons.

Display

The display simultaneously indicates the channel number, current gas reading, measuring unit, and target gas of all active channels.

The display also indicates messages, settings, and other data when you are operating the instrument programs.

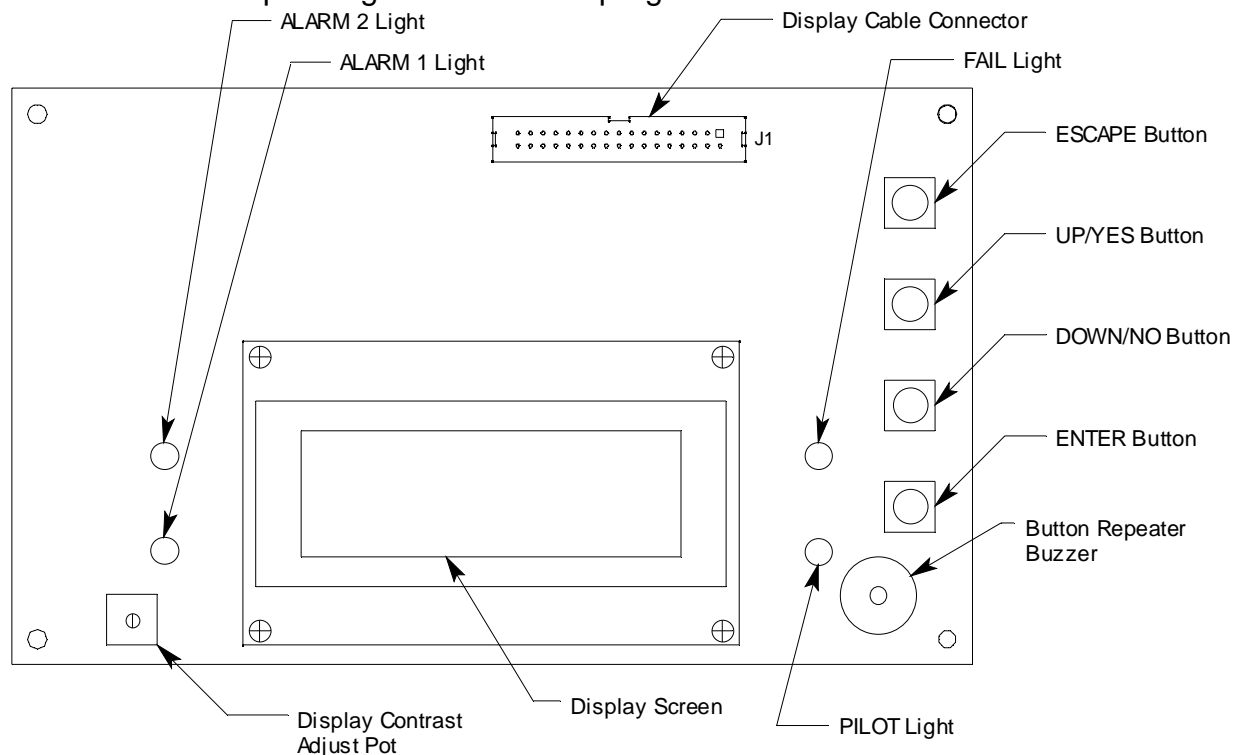

Figure 5. Display Board Component Location

Status Lights

The Rig Monitor includes four status lights that indicate the current status of the monitor. The status lights are to the left and right of the display (see Figure 5).

- **Pilot Light.** The pilot light is on when the Rig Monitor is receiving incoming power.
- **Fail Light.** The fail light turns on when the Rig Monitor is experiencing a fail condition. A fail condition can be caused by a failure within the Rig Monitor or detector head(s) wired to the Rig Monitor. See “Chapter 6: Maintenance” on page 33 for instructions to respond to a fail condition.
- **Alarm 1 Light.** The alarm 1 light is on when the Rig Monitor is experiencing an alarm 1 gas condition.
- **Alarm 2 Light.** The alarm 2 light is on when the Rig Monitor is experiencing an alarm 2 gas condition.

Program Buttons

The Rig Monitor includes four program buttons that allow you to enter the instrument programs, navigate through the programs, update instrument and channel settings, and save changes to the program settings. When a program button is pressed, a buzzer located on the display PCB beeps. The program buttons are near the right edge of the display PCB (see Figure 5).

Table 2: Beacon 200 Rig Monitor Program Button Functions

Button	Function
ESCAPE	<ul style="list-style-type: none">• Moves backward through the program menus• Cancels changes you make in the program menus• Enters the Channel Control and Setup program (press with the ENTER button)
UP/YES	<ul style="list-style-type: none">• Accepts the displayed setting and proceeds to the next setting• Changes the displayed setting• Enters the Calibration program (press with the ENTER button)
DOWN/NO	<ul style="list-style-type: none">• Allows you to update the displayed setting• Changes the displayed setting
ENTER	<ul style="list-style-type: none">• Saves changes you make in the programs• Enters the Channel Control and Setup program (press with ESCAPE button)• Enters the Calibration program (press with the UP/YES button)

Main PCB

The main PCB is mounted inside the housing. The power supply mounting plate is mounted to the main PCB with four standoffs and the display PCB is mounted to the power supply mounting plate with four standoffs. The main PCB includes the terminal strips, relays, fuses, and power switch.

Terminal Strips

The Rig Monitor includes four terminal strips for external wiring connections. See “Wiring the Beacon 200 Rig Monitor” on page 17 for detailed wiring procedures.

- **Detector/Transmitter Terminal Strips.** Two detector/transmitter terminal strips are located near the bottom left corner of the main circuit board (see Figure 1). These two 9-point terminal strips facilitate wiring connections to the detectors. Only one detector head at a time may be wired per channel. The top terminal strip is for channel 1 and the bottom terminal strip is for channel 2. The LEL detector is factory wired to the top terminal strip and the H₂S detector is factory wired to the bottom terminal strip.
- **Alarm Terminal Strip.** The alarm terminal strip is located along the bottom edge of the main circuit board (see Figure 1). This 21-point terminal strips facilitates wiring connections to external alarm devices (horn, strobe, etc.). Terminals are provided for individual channels as well as common alarm relay contacts. The horn/strobe is factory wired to this terminal strip.
- **Controller Terminal Strip.** The 10-point controller terminal strip is near the lower right edge of the main circuit board (see Figure 1). The controller terminal strip facilitates various internal and external wiring connections. Table 3 lists the function of each terminal.

Table 3: Terminal Assignments for the Controller Terminal Strip

Terminal	Connects to:
FACTORY WIRED (top terminal)	- connection from 12 VDC strobe, factory wired
FACTORY WIRED (bottom terminal)	not used
+ CH1 OUT	+ connection of 4 - 20 mA output, channel 1
- CH 1 OUT	- connection of 4 - 20 mA output, channel 1
+ CH2 OUT	+ connection of 4 - 20 mA output, channel 2
- CH2 OUT	- connection of 4 - 20 mA output, channel 2
RESET (2)	Reset switch (factory-wired)
BUZ-/BUZ+	Internal buzzer (factory-wired)

- **DC In Terminal Strip.** The DC in terminal strip is a 3-point terminal strip located above the controller terminal strip (see Figure 1). It facilitates wiring from the 12 VDC battery. The 50 foot battery cable is factory wired to this terminal strip. Table 4 lists the function of each terminal.

Table 4: Terminal Assignments for the AC In Terminal Strip

Terminal	Connects to:
+	White wire from battery cable
-	Black wire from battery cable
	Earth ground, factory wired

Relays

The Rig Monitor includes four channel relays (two per channel) and three common relays. Both sets of relays are single-pole, double-throw (SPDT) and are rated for 10 amps at 250 VAC (resistive).

NOTE: You can select normally energized (NE) or normally de-energized (NDE) settings for each channel in the Channel Control and Setup program. This section describes the default setting: normally de-energized.

The alarm 1 and alarm 2 common relays are factory-set as NDE and the fail common relay is factory-set as NE. The alarm 1, alarm 2, and fail common relays' NE/NDE settings are not user-adjustable.

- **Channel relays.** The four channel relays are above the alarm terminal strip (see Figure 1). These relays are dedicated to specific channels and alarm levels.

For example, the channel 1, alarm 1 relay energizes if channel 1 recognizes an alarm 1 condition. Figure 5 below illustrates the allocation of the channel relays.

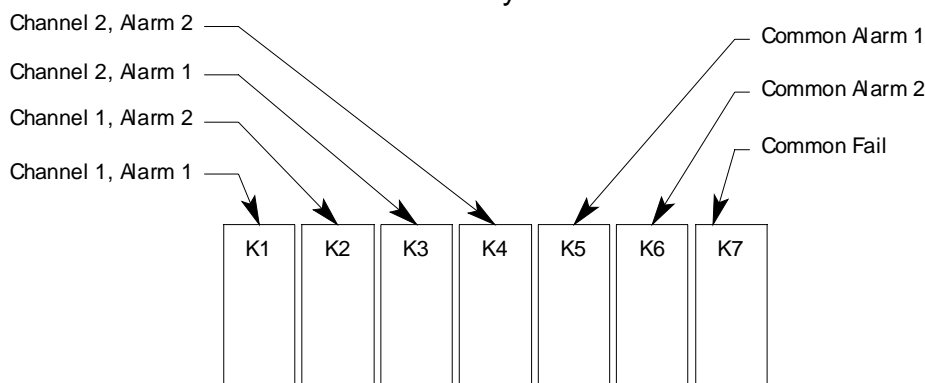

Figure 6. Beacon 200 Rig Monitor Channel Relay Allocation

NOTE: The alarm 2 channel relays may be set to operate as individual channel fail relays. See “Configure Channel Settings Menu” on page 30 for instructions.

- **Common relays.** The three common relays, alarm 1, alarm 2, and fail, are to the left of the controller terminal strip (see Figure 1). These relays are common for both channels.

For example, the alarm 1 common relay energizes if **either** channel 1 or channel 2 recognizes an alarm 1 condition. The common alarm 1 relay is factory wired to the strobe/horn and is not available for customer use.

Fuses

There are two DC fuses that are used in the Rig Monitor. They are located directly to the left of the controller terminal strip. They cut off the incoming DC power in the event of a short circuit or other electrical fault which causes a high current draw in the Rig Monitor. They are housed in vertical fuse holders and are held in the holder by a quarter turn cover. They are labelled as F2 (top fuse) and F3 (bottom fuse) on the PCB silk-screen and are rated at 3 A, 250 V.

Power Switch

The power switch is located above the relays and to the left of the DC fuses (see Figure 1). The power switch turns the incoming DC power source on and off at the Rig Monitor. When the switch is up, the power switch is on.

Power Converter

The power converter is mounted to the power supply mounting plate with standoffs. The power supply mounting plate is located behind the display PCB and is mounted to the main PCB with four standoffs. The power converter takes 12 VDC voltage supplied to the Rig Monitor and converts it to 24 VDC which is used to run the Rig Monitor.

Chapter 3: Installation and Start Up

Overview

This chapter describes procedures to mount the Beacon 200 Rig Monitor, make wiring connections to the monitor, and start up the monitor.

WARNING: Perform all installation and start-up procedures in a “fresh air” environment (known to be free of combustible gas, toxic gas, and of normal oxygen content). The Beacon 200 Rig Monitor is not in operation as a gas monitoring system until the start-up procedure is complete.

Mounting the Beacon 200 Rig Monitor

Perform the following procedure to install the Beacon 200 Rig Monitor at the mounting site.

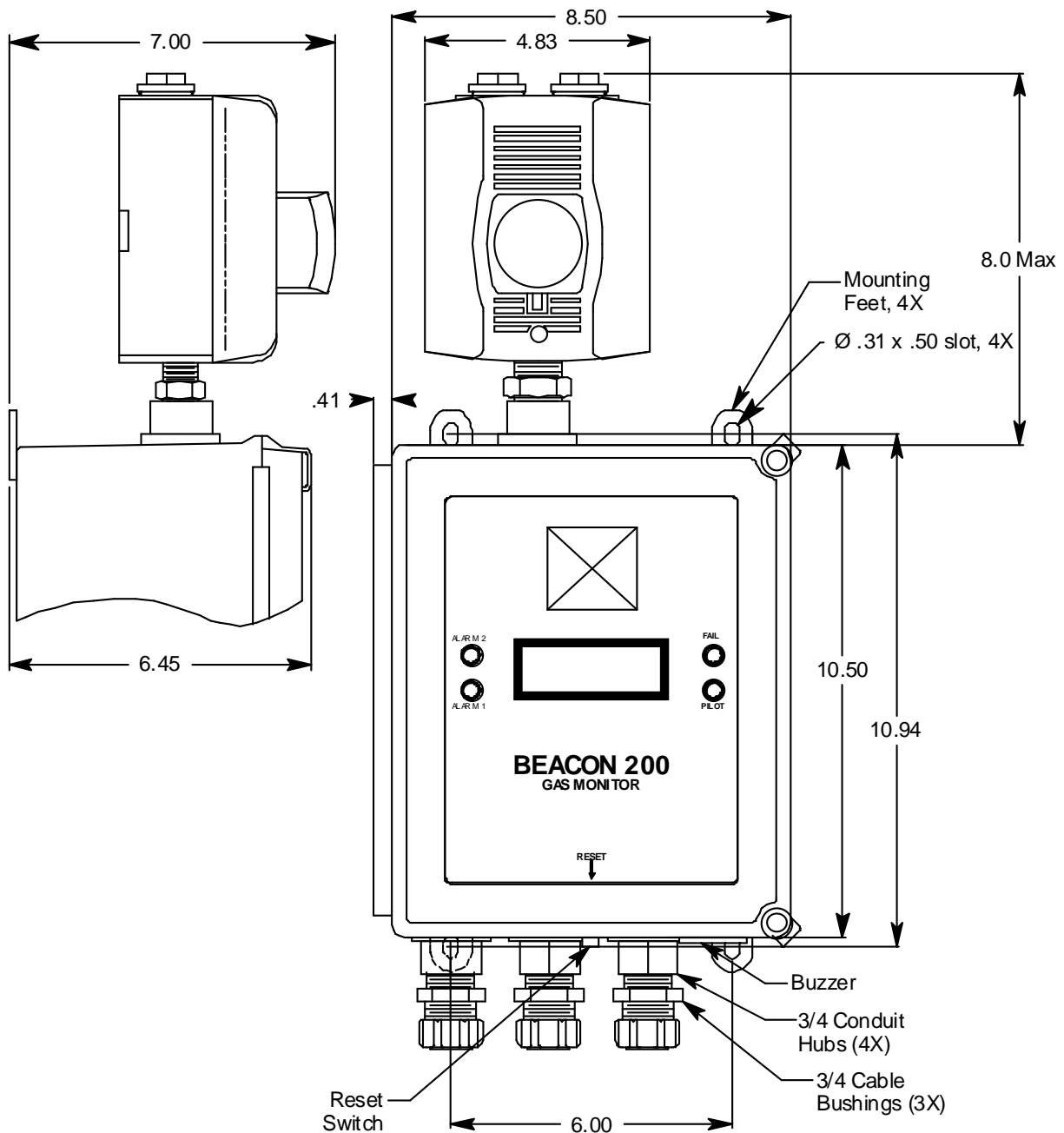

Figure 7. Rig Monitor Outline and Mounting Dimensions

1. Select the mounting site. When you select the mounting site consider the following factors:
 - Can the 12 VDC battery be installed within 50 feet of the Rig Monitor?
 - Is there enough room to open the housing door and make wiring connections through the conduit hubs at the bottom of the housing?
 - Are the display screen and status lights visible?

2. Close and latch the housing door.
3. Position the monitor on a vertical surface at eye level (4 1/2 to 5 feet from the floor).
4. The Rig Monitor is shipped with the mounting feet positioned behind the housing. Loosen the screws that secure the feet to the housing, rotate the feet to their mounting position (as shown in Figure 7), then tighten the screws.
5. Insert 1/4 in. or 5/16 in. screws through the slots in the mounting feet at each corner of the housing to secure the housing to the mounting surface (see Figure 7).
6. Hang the LEL and H₂S detector junction boxes using the mounting brackets. Ensure that the detectors are facing down.

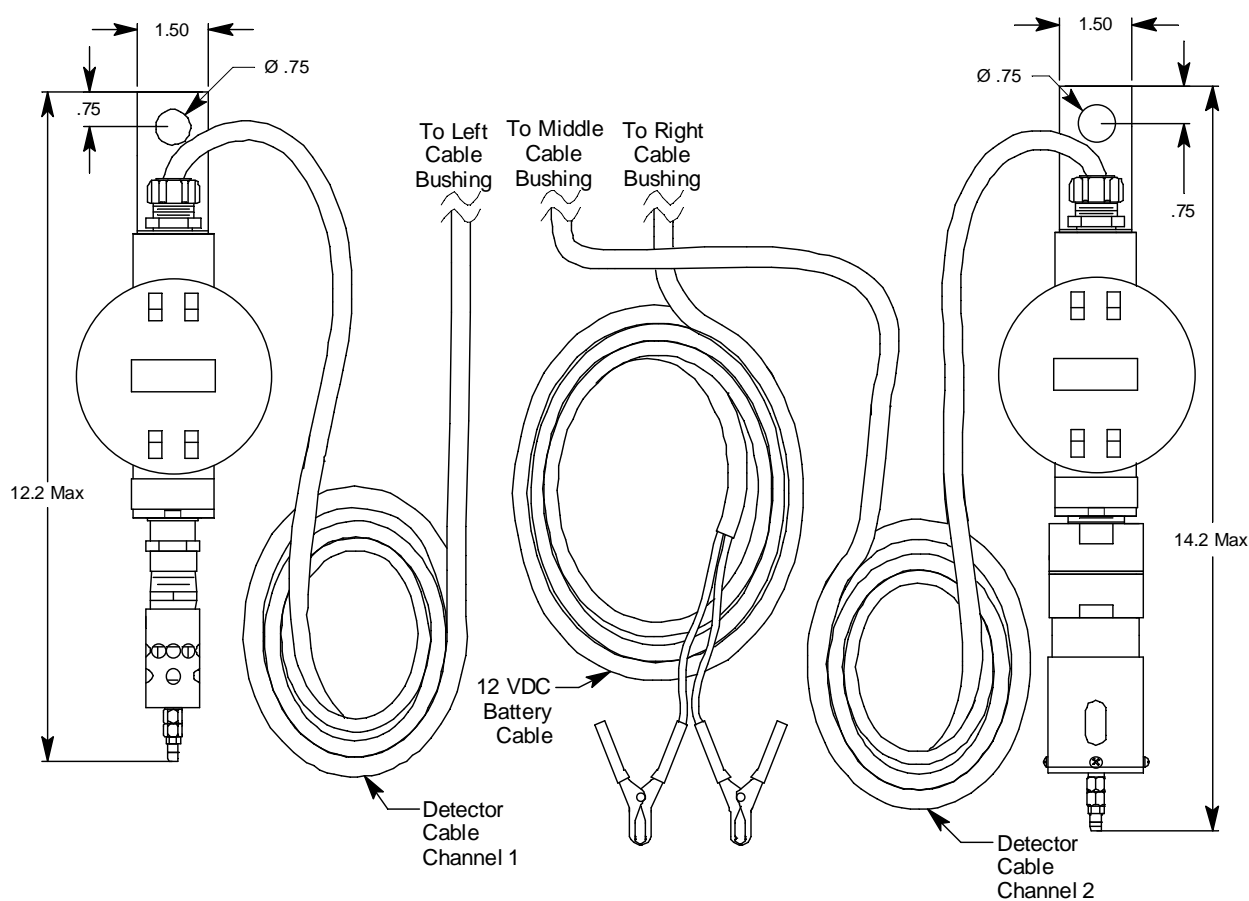

Figure 8. LEL and H₂S Detector Outline and Mounting Dimensions

Wiring the Beacon 200 Rig Monitor

The detector leads, junction box connections, power cable wiring, and strobe/horn wiring are all factory wired.

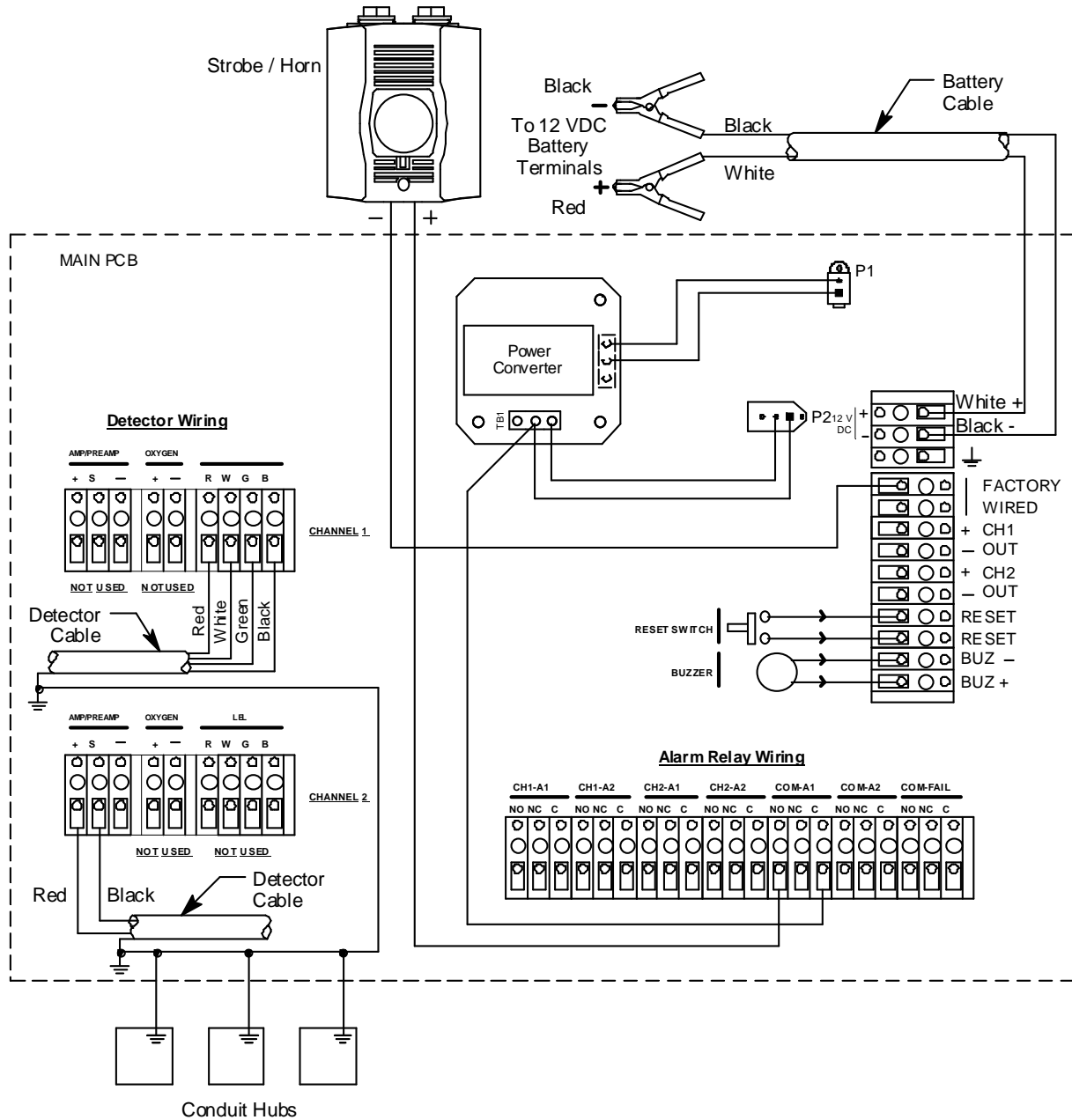

Figure 9. Beacon 200 Rig Monitor Factory Wiring Diagram

WARNING: *Make all connections to the Beacon 200 Rig Monitor before you connect the DC power source. Before you make any wiring adjustments, always verify that all power sources are not live.*

Connecting the DC Power Source

Perform the following functions to connect the Rig Monitor to DC power. One end of the battery cable is already factory wired to the appropriate terminals at the Rig Monitor housing. Use the other end to connect a 12 VDC battery.

NOTE: Be sure to turn off the Beacon 200 Rig Monitor before connecting or disconnecting it from the 12 VDC battery.

1. Turn off, unplug, or disconnect all incoming power to the Rig Monitor.
2. Open the housing door, then place the power switch in the OFF position.
3. Connect the red battery clamp to the (+) terminal of the 12 VDC battery.
4. Connect the black battery clamp to the (-) terminal of the 12 VDC battery.

Connecting External Alarms

Perform the following procedure to connect external alarm devices to the Rig Monitor. The common alarm 1 terminals are factory wired and are not available for field use.

NOTE: The alarm terminal strip includes terminals for **channel** alarms and **common** alarms. Channel alarms are activated by one particular channel. Common alarms are activated by either of the two channels. The example used in this procedure describes connecting an external alarm device to one of the channel alarm terminals: the channel 1, alarm 1 terminals.

1. Disconnect the battery clamps from the + and - terminals of the 12 VDC battery.
2. Open the housing door, then place the power switch in the OFF position. Locate the alarm terminal strip (see Figure 1).
3. Install an appropriately rated cable bushing in the Rig Monitor housing. All factory supplied conduit hubs are used in the Rig Monitor, so you will need to drill a hole in the housing for a conduit hub and cable bushing.

4. Guide the wiring of the external alarm device through the new conduit hub on the bottom of the Rig Monitor housing.
5. Connect the leads from the external alarm device and power to the alarm terminals as shown in Figure 10.

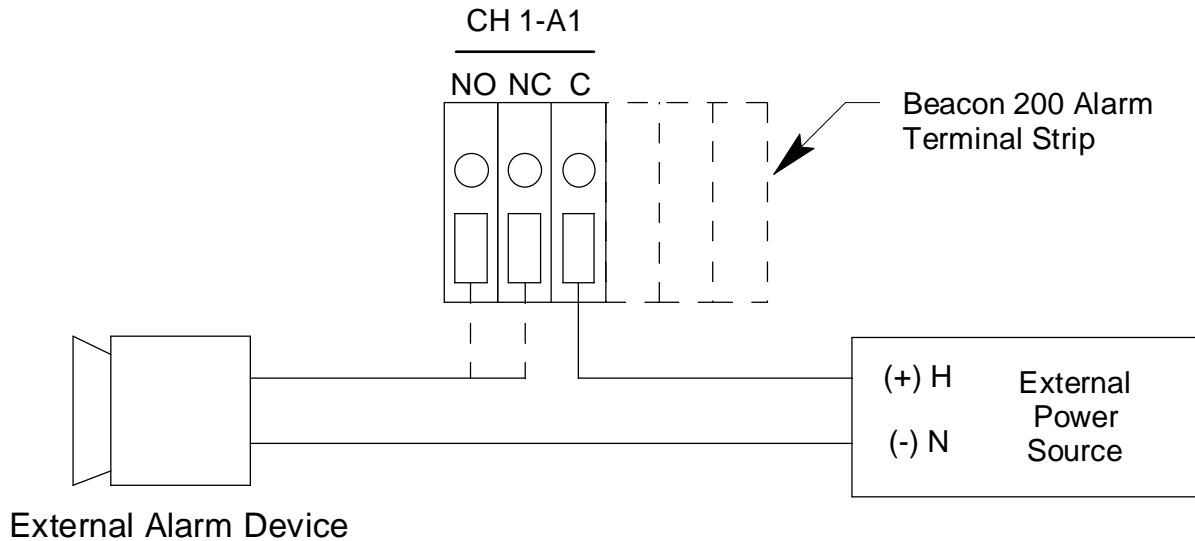

Figure 10. Typical External Alarm Wiring

6. Repeat steps 4 and 5 for additional external alarm devices.

Connecting a Recorder

Perform the following procedure to connect an analog recording device to the Rig Monitor. The output at the recorder output terminals is a 4 - 20 mA signal that is proportional to the detection range of the applicable detector head.

1. Disconnect the battery clamps from the + and - terminals of the 12 VDC battery.
2. Open the housing door, then place the power switch in the OFF position. Locate the recorder output terminals on the controller terminal strip (see Figure 1).
3. Install an appropriately rated cable bushing in the Rig Monitor housing. All factory supplied conduit hubs are used in the Rig Monitor, so you will need to drill a hole in the housing for a conduit hub and cable bushing.
4. Guide the wiring from the recording device through the new conduit hub on the Rig Monitor.

5. Connect the wires from the recording device to the recorder output terminals as shown in Figure 11.

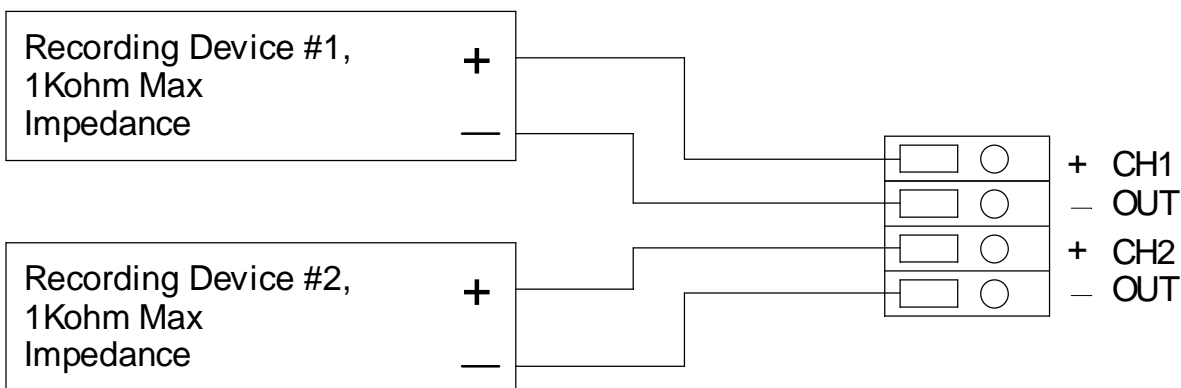

Figure 11. Recorder Output Wiring

Starting Up the Beacon 200 Rig Monitor

Perform the following procedure to place the Beacon 200 Rig Monitor into normal operation.

1. Complete the mounting and wiring procedures described earlier in this chapter.
2. Verify that all wiring connections are correct and secure and that the Rig Monitor's power switch is in the OFF position.
3. If not already connected, connect the battery clamps to the + and - terminals of the 12 VDC battery.
4. Place the Rig Monitor's power switch in the ON position. **RKI INSTRUMENTS BEACON 200** appears on the display for a few seconds, then **WARMING UP** appears for each active channel. The warm-up period will last for one minute.

NOTE: To prevent unwanted alarms during warm up, the alarm circuits are not active while the **WARMING UP** message is displayed.

5. Verify that the PILOT light is on. If the PILOT light is not on, see "Troubleshooting" on page 46.
6. The LEL and H₂S detectors will begin operating once power is introduced to the Rig Monitor.

Chapter 4: Operation

Overview

This chapter describes the Beacon 200 Rig Monitor in normal operation. This chapter also describes the Rig Monitor in alarm 1, alarm 2, and fail conditions and suggests response to these conditions.

Normal Operation

Normal operation is defined as follows:

- The start-up procedure is complete.
- The Rig Monitor is not indicating an alarm 1, alarm 2, or fail condition.
- The Rig Monitor is not running the Channel Control & Setup or Calibration Programs.

During normal operation, the Rig Monitor simultaneously displays the current gas reading, unit of measure, and target gas for each active channel.

1:	0 %LEL CH4
2:	0 ppm H2S

The PILOT light is on during normal operation indicating that the Rig Monitor is receiving incoming power.

Recorder Output Operation

The output at the recorder output terminals is a 4 - 20 mA signal for each active channel that is proportional to the detection range of the channel. A channel that is set as CHANNEL NOT USED or CHANNEL DISABLED in the Channel Control & Setup Program (see “Chapter 5: Channel Control and Setup Program” on page 28) has an output of 0 mA.

There are several special circumstances where the recorder output will behave as follows:

- When a channel is in WARMUP after the Rig Monitor is turned on, the recorder output will be at 4 mA.
- If the Rig Monitor is being powered by a battery and is in low battery alarm, the recorder output for each channel will be 0 mA.
- When a channel is added or a channel type changed, the display will indicate NEEDS CALIBRATION for that channel when the Rig Monitor is first turned on and will continue to indicate this until the channel is calibrated. In this situation, the recorder output will be at 3.2 mA until the channel is calibrated.
- If a channel goes into a fail condition, the recorder output will be 0 mA.
- If you enter any of the instrument programs, such as the Calibration Program, the recorder output will hold at the value it was at when you entered the program was entered until you return to normal operation.

Alarm Indications

This section describes the Rig Monitor in alarm 1, alarm 2, and fail conditions and suggests response to these conditions. Table 5 below lists the alarm indications for each condition.

NOTE: The Beacon 200 Rig Monitor includes alarm on and alarm off delay settings for each channel and level of gas alarm. The alarm indications described in this section operate according to the factory set delay settings. See “Configure Channel Settings Menu” on page 30 for all the factory settings.

Table 5: Visual and Audible Alarm Indications

Condition	Cause	Visual Indication(s)	Audible Indication
Alarm 1 ¹	Increasing gas reading at or above the alarm 1 setpoint	<ul style="list-style-type: none"> ALARM 1 light is on Gas reading flashes and alternates with ALARM-1 message Strobe/horn turns on 	Pulsing tone
Alarm 2 ¹	Increasing gas reading at or above the alarm 2 setpoint	<ul style="list-style-type: none"> ALARM 2 light is on Gas reading flashes and alternates with ALARM-2 message 	Pulsing tone
Fail	<ul style="list-style-type: none"> Disconnected or misconnected detector wiring Display reading below -10% of full scale or lower Defective components 	<ul style="list-style-type: none"> FAIL light is on FAIL message flashes in place of gas reading 	Steady tone
Low Battery	Dead 12 VDC battery.	<ul style="list-style-type: none"> FAIL light is on SUPPLY VOLTAGE IS TOO LOW LOW POWER STANDBY message and actual voltage of incoming DC power 	None
<p><i>NOTE: Under typical operating conditions, there will be no low power alarm. The 12 VDC battery that is recommended for operation will die before the power converter recognizes a low power condition.</i></p>			
<p>* <i>¹If the Beacon 200 is in both an alarm 1 and an alarm 2 condition, both alarm lights are on and the display alternates between the gas reading and the ALARM-1 ALARM-2 message.</i></p>			

NOTE: You can select normally energized (NE) or normally de-energized (NDE) channel relay settings in the Channel Control & Setup menu. The following sections describe the default setting for the channel relays which is NDE.

Common alarm 1 and alarm 2 relays are factory-set as NDE, and the common fail relay is factory set as NE. The common relays' NE/NDE settings are not user-adjustable.

Alarm 1 Condition

This section describes the audible and visual indications for an alarm 1 condition and suggests response to an alarm 1 condition.

Alarm 1 Condition Indications

When the gas reading of an active channel reaches the alarm 1 setpoint, the Rig Monitor senses an alarm 1 condition. The Rig Monitor alerts you to an alarm 1 condition as follows:

- The ALARM 1 light turns on.
- The gas reading in alarm 1 condition flashes and alternates with the **ALARM-1** message.
- The buzzer sounds a Pulsing tone.
- The common alarm 1 relay energizes and the strobe/horn activates.
- The applicable alarm 1 channel relay energizes.

Responding to an Alarm 1 Condition

This section suggests response to an alarm 1 condition.

1. Follow your established procedure for a low level combustible gas or H₂S condition.
2. Alarms are latching. After the gas reading falls below the alarm 1 setpoint, press the reset switch to reset the alarm 1 circuit. Resetting the alarm 1 circuit silences the buzzer, turns off the ALARM 1 light, resets the channel display, de-energizes the common and channel alarm 1 relays, and turns off the strobe/horn.

NOTE: To silence the buzzer while in an alarm 1 condition, press the reset switch.

You cannot de-energize the alarm 1 relays and consequently the strobe/horn until the gas reading falls below the alarm 1 setpoint.

Alarm 2 Condition

This section describes the audible and visual indications for an alarm 2 condition and suggests response to an alarm 2 condition.

Alarm 2 Condition Indications

When the gas reading of an active channel reaches the alarm 2 setpoint, the Rig Monitor senses an alarm 2 condition. The Rig Monitor alerts you to an alarm 2 condition as follows:

- The ALARM 2 light turns on.
- The gas reading in alarm 2 condition continues to flash and alternates with the **ALARM-2** messages.
- The buzzer sounds a Pulsing tone.
- The common alarm 2 relay energizes.
- The applicable alarm 2 channel relay energizes.

Responding to an Alarm 2 Condition

This section suggests response to an alarm 2 condition.

1. Follow your established procedure for a high level combustible gas or H₂S condition.
2. Alarms are latching. After the gas reading falls below the alarm 2 setpoint, press the reset switch to reset the alarm circuit. Resetting the alarm circuit turns off the ALARM 2 light, and de-energizes the common and channel alarm 2 relays.

NOTE: To silence the buzzer while in an alarm 2 condition, press the reset switch.

You cannot de-energize the alarm 2 relays until the gas reading falls below the alarm 2 setpoint.

Fail Condition

This section describes the audible and visual indications for a fail condition and suggests response to a fail condition.

Fail Condition Indications

The Rig Monitor senses a fail condition for any of the following:

- The detector head wiring to the Rig Monitor is disconnected or incorrectly connected.
- The detector head's detector is disconnected or incorrectly connected.

- The display reading is -10% of full scale or lower.
- The Rig Monitor or detector head is malfunctioning.

When the Rig Monitor senses a fail condition, it alerts you as follows:

- The FAIL light turns on.
- The gas reading for the failing channel is replaced by the **FAIL** message.
- The buzzer sounds a steady tone.
- The common fail relay de-energizes.

NOTE: If you elected to use the channel's alarm 2 relay as an individual fail relay in the Channel Control & Setup menu, the relay de-energizes in a fail condition. See "Chapter 5: Channel Control and Setup Program" on page 28 for a description of this setting.

Responding to a Fail Condition

This section suggests response to a fail condition.

1. Verify that the detector head wiring to the Rig Monitor is correctly and securely connected.
2. Verify that the detector head's detector is correctly and securely connected.
3. See the troubleshooting guide in the detector head instruction manual.

Low Battery Condition

The 12 VDC battery that is recommended for operation of the Rig Monitor is typically dead before the power converter recognizes a low power condition. As a result, when the Rig Monitor is used with a 12 VDC battery, there may be no low power alarm and the unit will instead shut off once the battery is dead.

Viewing & Resetting Min/Max Readings

The Reset switch may be used to view and reset the minimum and maximum gas readings for the active channel(s).

1. While the Rig Monitor is in normal operation, press and hold the Reset switch button for 3 seconds.
2. The display will indicate **MIN / MAX Display Press RESET when done viewing . . .** for 5 seconds before displaying the minimum and maximum readings for the active channel(s). The minimum reading is on the left and the maximum is on the right side of the display for each channel.
3. Press and release the Reset switch button to exit the min/max screen. The display will indicate **To RESET Min/MAX values Press and HOLD RESET Button** for 10 seconds and then return to normal operation.
 - To return to normal operation without resetting the minimum and maximum readings, do not press the Reset switch button and allow the unit to return to normal operation.
 - To reset the minimum and maximum readings, before the unit returns to normal operation press and hold the Reset switch button until the display indicates **Min/Max Values Have Been Reset.** Release the Reset switch button. The unit will then return to normal operation.

Chapter 5: Channel Control and Setup Program

Overview

The Channel Control & Setup Program allows viewing of and changes to instrument setup parameters. It is accessed using the program buttons. The Channel Control & Setup Program includes three menus as described in Table 6.

Table 6: Channel Control & Setup Program Menus

Menu	Function
Enable/Disable Channel(s)	Configures channels as enabled, disabled, or not used
Configure Channel Settings	Configures alarm settings, noise filter setting, and zero suppression setting for each channel
View System Information	Displays the firmware version number and the instrument operating voltage

To enter the Channel Control & Setup Program, simultaneously press and hold the ESCAPE and ENTER buttons for approximately 5 seconds.

The Channel Control & Setup Program menu includes a 5-minute time-out feature. If you do not press a button for 5 minutes, the Rig Monitor automatically returns to normal operation.

NOTE: If the Beacon 200 Rig Monitor returns to normal operation because of a program time-out, the active channels enter a warm-up period just as they do when the unit is first turned on.

If you are installing a new system, the channels have been setup at the factory for the ordered detector heads. Use the Channel Control & Setup Program only if you want to disable or enable a channel, delete a channel, or change channel settings. If a channel is being added or a channel is being changed from one type to another, contact RKI Instruments, Inc. for additional documentation required to define the channel type.

Enable/Disable Channel(s) Menu

1. From normal operation, simultaneously press and hold the ESCAPE and ENTER buttons for approximately 5 seconds to enter the Channel Control & Setup Program. Release the buttons when the **Control & Setup Program Proceed? [YES] or [NO]** message appears on the display screen.
2. Press the UP/YES button to continue.
3. Press the UP/YES or DOWN/NO button until the **1) Enable/Disable Channel(s)** message appears on the display screen, then press the ENTER button.
4. Use the UP/YES and DOWN/NO buttons to select the channel you want to enable or disable, then press the ENTER button.
5. Press the DOWN/NO button. The CHANNEL USAGE setting displays on the display screen.
6. Use the UP/YES and DOWN/NO buttons to display the setting you want, then press the ENTER button to select the setting. The table below describes the three available settings.

Table 7: Beacon 200 Channel Usage Settings

Setting	Description
CHANNEL ENABLED	The Rig Monitor displays gas readings and initiates gas and channel failure alarms when appropriate. Use this setting for normal operation when the channel has a detector head wired to it.
CHANNEL DISABLED	The Rig Monitor displays DISABLED for the channel and the channel's alarm circuit is not active. Use this setting when the channel has a detector head wired to it, but gas readings and alarms are not required for the channel (for example if the detector head requires maintenance or is malfunctioning).
CHANNEL NOT USED	The Rig Monitor leaves the channel blank on the display screen. Use this setting when the channel does not have a detector head wired to it.

7. Press the ESCAPE button, then press the DOWN/NO button to return to normal operation.

Configure Channel Settings Menu

This section describes how to view and change channel parameters for the installed gas channels.

1. Simultaneously press and hold the ESCAPE and ENTER buttons for approximately 5 seconds to enter the Channel Control & Setup Program. Release the buttons when the **Control & Setup Program Proceed? [YES] or [NO]** message appears on the display screen.
2. Press the UP/YES button to continue.
3. Press the UP/YES or DOWN/NO button until the **2) Configure Channel Setting(s)** message appears on the display screen, then press the ENTER button.
4. Use the UP/YES and DOWN/NO buttons to select the channel for which you want to set parameters, then press the ENTER button.
5. Press the UP/YES button until the parameter you want to set appears on the display screen. The screen will display the current setting and ask if it is OK.

Table 8 lists the parameters you can set for a channel. Table 8 also lists the factory set value for each parameter.

NOTE: Use the ESCAPE button to go back to a previously displayed parameter.

6. If the setting is not OK and you want to change the it, press the DOWN/NO button. The parameter is now adjustable.
7. Use the UP/YES or DOWN/NO button to update the parameter, then press the ENTER button to continue.
8. Repeat steps 5 through 7 to set any other channel parameters.
9. Press the UP/YES button until the following message appears on the display screen.

```
Configuration for
-- CHANNEL 1 --
has been completed
Save Settings? [Y/N]
```

10. Press the UP/YES button to save the configuration. The screen will then return to the Channel Control & Setup menu.
11. To view or change the Channel 2 settings, scroll to the Configure Channels Menu and repeat steps 4 through 10.
12. To exit the Channel Control & Setup menu, press ESCAPE to return to the screen which asks **Control & Setup Program Proceed? [YES] or [NO]**.
13. Press the DOWN/NO button to return to normal operation.

Table 8: Channel Setting Parameters

Parameter (Factory-Set Value)	Description
ALARM-1 Level (10 %LEL or 10 ppm H ₂ S)	The gas reading at which the Rig Monitor initiates an alarm 1 condition.
ALARM-1 ON DELAY (1 sec)	The amount of time the Beacon 200 delays activation of the alarm 1 circuit once an alarm 1 condition is initiated.
ALARM-1 OFF DELAY (0 sec)	The amount of time the Beacon 200 delays turning off the alarm 1 circuit once an alarm 1 condition passes.
ALARM-1 (activation) (INCREASING)	Indicates if the alarm 1 circuit is activated by gas readings INCREASING or DECREASING to the ALARM-1 Level. <i>Note: Changing this parameter will affect the operation of the factory installed strobe/horn. Do not change this parameter from the factory setting.</i>
ALARM-1 Relay (action) (NORMALLY DE-ENERGIZED)	If set as NORMALLY DE-ENERGIZED , the channel's alarm 1 relay is de-energized in normal operation and energizes when an alarm 1 condition is initiated. If set as NORMALLY ENERGIZED , the channel's alarm 1 relay is energized in normal operation and de-energizes when an alarm 1 condition is initiated. <i>Note: Changing this parameter will affect the operation of the factory installed strobe/horn. Do not change this parameter from the factory setting.</i>
ALARM-1 Relay (reset) (LATCHING)	If set as LATCHING , you must press the RESET button to reset the alarm 1 circuit after the alarm 1 condition passes. If set as SELF RESETTING , the Rig Monitor automatically resets the alarm 1 circuit after the alarm 1 condition passes.
ALARM-2 Relay (used for) (ALARM-2 Condition)	If set as ALARM-2 Condition , the channel's alarm 2 relay activates when an alarm 2 condition is initiated for the channel. If set as FAIL Condition , the channel's alarm 2 relay activates when a fail condition is initiated for the channel.
ALARM-2 Level (50 % LEL or 50 ppm H ₂ S)	The gas reading at which the Rig Monitor initiates an alarm 2 condition.
ALARM-2 ON DELAY (1 sec)	The amount of time the Rig Monitor delays activation of the alarm 2 circuit once an alarm 2 condition is initiated.

Table 8: Channel Setting Parameters (Continued)

Parameter (Factory-Set Value)	Description
ALARM-2 OFF DELAY (0 sec)	The amount of time the Rig Monitor delays turning off the alarm 2 circuit once an alarm 2 condition passes.
ALARM-2 (activation) (INCREASING)	Indicates if the alarm 2 circuit is activated by gas readings INCREASING or DECREASING to the ALARM-2 Level.
ALARM-2 Relay (action) (NORMALLY DE-ENERGIZED)	If set as NORMALLY DE-ENERGIZED , the channel's alarm 2 relay is de-energized in normal operation and energizes when an alarm 2 condition is initiated. If set as NORMALLY ENERGIZED , the channel's alarm 2 relay is energized in normal operation and de-energizes when an alarm 2 condition is initiated.
ALARM-2 Relay (reset) (LATCHING)	If set as LATCHING , you must press the RESET button to reset the alarm 2 circuit after the alarm 2 condition passes. If set as SELF RESETTING , the Rig Monitor automatically resets the alarm 2 circuit after the alarm 2 condition passes.
NOISE FILTER (3)	The noise filter feature helps “smooth out” jumpy or noisy signals from the detector head. You can set the noise filter from 1 to 8. A setting of 8 produces the greatest amount of smoothing but also responds slowest to changes in the response reading. A setting of 1 responds fastest to changes in the response reading but produces the least amount of smoothing.
ZERO SUPPRESSION (2% of full scale)	The zero suppression feature helps prevent “jumpy” readings near the fresh air reading. For example, if the zero suppression setting on the H ₂ S channel is 2% of full scale , the Rig Monitor will display a reading of 0 ppm for gas readings from -2 ppm to 2 ppm.

View System Information Menu

The View System Information Menu consists of only one display screen which indicates the version number of the firmware that is running the instrument and the system voltage. The system voltage is the voltage that is directly running the instrument's circuitry.

NOTE: The Information Screen is not a good indicator of battery life because the power converter will operate as normal and have an output of 24 volts until the 12 VDC battery dies.

Chapter 6: Maintenance

Overview

This chapter describes use of the Calibration Program and corrective maintenance procedures for the Beacon 200 Rig Monitor. It includes a troubleshooting guide for problems you may encounter with the Beacon 200 Rig Monitor. Procedures to replace components of the Rig Monitor are at the end of this chapter.

Calibration Program

The Calibration Program is used to calibrate the Rig Monitor's active channel(s).

Calibration Program Flow

Figure 12 below illustrates the general flow of the Calibration Program. See the next section, Preparing for Calibration, for instructions to enter the Calibration Program. In general, the program screens provide instructions to guide you through the program. At any point in the calibration program, the ESCAPE key may be used to either return to the previous screen or abort a process.

NOTE: While in the Calibration Program, the alarm status of the Beacon 200 Rig Monitor will be locked in the state it was when the Calibration Program was entered.

2. Press the ENTER button to continue and display the Calibration Time-out setting.

The Rig Monitor will remain in the Calibration Program for the amount of time indicated by the Calibration Time-out setting or until you exit the program. If necessary, adjust the setting using the UP/YES and DOWN/NO buttons. Make sure you have allotted enough time to perform the calibration procedure. Consider the type of detector head(s) installed and the distance from the Rig Monitor when determining the time required.

NOTE: If you do not accept a Time-out setting and stay at this screen or press ESCAPE and do not press control buttons again, then the Rig Monitor will exit the Calibration Program and begin its warm-up period 5 minutes after the last button was pushed. This warm-up period functions as if the unit were just powered up.

3. Press the ENTER button to accept the Time-out setting, start the Time-out period and continue in the Calibration Program.

Adjusting the Fresh Air Reading

1. The display asks if you want to calibrate channel 1. Press the UP/YES button to continue with calibrating channel 1.

If you press the DOWN/NO button, the display will skip to channel 2.

2. The display will ask if you want to calibrate channel 2. Press the UP/YES button to continue with calibrating channel 2.

If you press the DOWN/NO button, the calibration of channel 1 will continue if you selected it or if you did not select channel 1, the unit will return to the first calibration program screen which asks if you want to continue or escape the program.

3. If you pressed the UP/YES button for either channel, the unit will display the following message for a few seconds before continuing: **Expose Dectector(s) To Fresh Air. . . When Done Press ENTER.** Then the display will alternate between the gas reading for the selected channel(s) and the message **FRESH AIR ENTER to ACCEPT ESCAPE to ABORT** above the time remaining in the calibration Time-out. The following instructions assume you pressed the UP/YES button for both channels.

4. Screw the fixed flow regulator into the zero air calibration cylinder.
5. Use the calibration kit sample tubing to connect the fixed flow regulator to the calibration cup/splash guard of the LEL detector.
6. Turn the regulator knob counterclockwise to open the regulator.
7. Allow zero air to flow for two minutes.
8. Turn the regulator knob clockwise to close the regulator. The Rig Monitor will continue to display the minimum gas response on the display and retain the response level in its memory.
9. Disconnect the sample tubing from the LEL detector and connect it to the calibration cup/splash guard hose barb of the H₂S detector.
10. Turn the regulator knob counterclockwise to open the regulator.
11. Allow zero air to flow for two minutes.
12. Turn the regulator knob clockwise to close the regulator. The Rig Monitor will continue to display the minimum gas response on the display and retain the response level in its memory.
13. Press the ENTER button at the Rig Monitor. The unit will adjust the zero reading and display the message **Fresh Air Adjust Passed for: Channel 1 Channel 2** before continuing.
14. If you applied zero air to the detectors, unscrew the regulator from the zero air calibration cylinder.
15. If you applied zero air to the detectors, leave the sample tubing connected to the regulator and move it from the H₂S detector to the LEL detector's calibration cup/splash guard.

If you did not apply zero air to the detectors, use the calibration kit sample tubing to connect the fixed flow regulator to the calibration cup/splash guard of the LEL detector.

NOTE: If the fresh air adjustment fails, see "Troubleshooting" on page 46 for recommended actions.

Adjusting the Span Setting

1. The display asks if you want to perform a span operation on channel 1 by applying gas. Press the UP/YES button to continue with adjusting the span on channel 1.

If you press the DOWN/NO button, the unit will skip to channel 2.
2. The display asks if you want to perform a span operation on channel 2 by applying gas. Press the UP/YES button to continue with adjusting the span on channel 2.

If you press the DOWN/NO button, the span of channel 1 will continue if you selected it or if you did not select channel 1, the unit will return to the first calibration program screen which asks if you want to continue or escape from the Calibration Program.

3. If you pressed the UP/YES button for either channel, the display will prompt you for the span gas concentration that will be used for the first selected channel. The following instructions assume you pressed UP/YES button for each channel.
4. Adjust the displayed concentration for channel 1 up or down as needed using the UP/YES and DOWN/NO buttons so that it matches the concentration in the calibration cylinder.
5. Press the ENTER button to accept the calibration gas concentration for Channel 1 and continue.
6. The display will then prompt you for the span gas concentration that will be used for channel 2. Adjust the displayed concentration up or down as needed using the UP/YES and DOWN/NO buttons so that it matches the concentration in the calibration cylinder.
7. Press the ENTER button to accept the calibration gas concentration for Channel 2 and continue.
8. The unit will display the message **Expose Dectector(s) To Gas. . .**
When Done Press ENTER for a few seconds. It will then alternate between the gas readings for both channels and the message **APPLYING GAS ENTER to ACCEPT ESCAPE to ABORT** above the time remaining in the calibration time-out.
9. Screw the calibration gas cylinder for the LEL detector onto the fixed flow regulator.

NOTE: Be sure that you are using an appropriate calibration cylinder for the channel you are calibrating.

10. Turn the regulator knob counterclockwise to open the regulator.
11. Allow calibration gas to flow for one minute.
12. Turn the regulator knob clockwise to close it. The Rig Monitor will continue to display the maximum gas response on the display and retain the response level in its memory.
13. Disconnect the sample tubing from the LEL detector. Unscrew the LEL calibration gas cylinder from the regulator and screw the H₂S calibration gas cylinder onto the regulator.

NOTE: Be sure that you are using an appropriate calibration cylinder for the channel you are calibrating.

14. Connect the sample tubing to the calibration cup/splash guard hose barb of the H₂S detector.

15. Turn the regulator knob counterclockwise to open the regulator.

16. Allow the calibration gas to flow for two minutes.

17. Turn the regulator knob clockwise to close the regulator. The Rig Monitor will continue to display the maximum gas response on the display and retain the response level in its memory.

18. Press the ENTER button at the Rig Monitor to proceed with the calibration adjustment.

If the Rig Monitor is able to successfully make the calibration adjustment, it will display the message **Cal Passed for: Channel 1 Channel 2**. It will then return to the first calibration program screen which asks if you want to continue or escape from the program. Press ESCAPE to return to normal operation.

If the Rig Monitor is not able to make the calibration adjustment, it will display the message **Not Enough Response! CAL Failed for: Channel 1 Channel 2**, then return to the first calibration program screen which asks if you want to continue or escape from the program. Press ENTER to start the calibration process again or ESCAPE to return to normal operation.

19. Unscrew the H₂S calibration gas cylinder from the fixed flow regulator and disconnect the sample tubing from the calibration cup/splash guard hose barb.

NOTE: Be sure to allow enough time between the application of calibration gas and returning to normal operation for the gas reading to return to normal levels to avoid false alarms. The alarm circuits are active when the Beacon 200 Rig Monitor returns to normal operation.

20. Store the components of the calibration kit in a safe place.

Adjusting Strobe/Horn Volume

The horn volume on the strobe/horn can be adjusted by doing the following:

1. Open the housing door of the Rig Monitor, then place the power switch in the OFF position.
2. Disconnect the battery clamps from the + and - terminals of the 12 VDC battery.
3. Loosen the captive screw at the bottom front of the strobe/horn.
4. Grasp the top and bottom of the strobe/horn and push up and out in order to remove the cover.

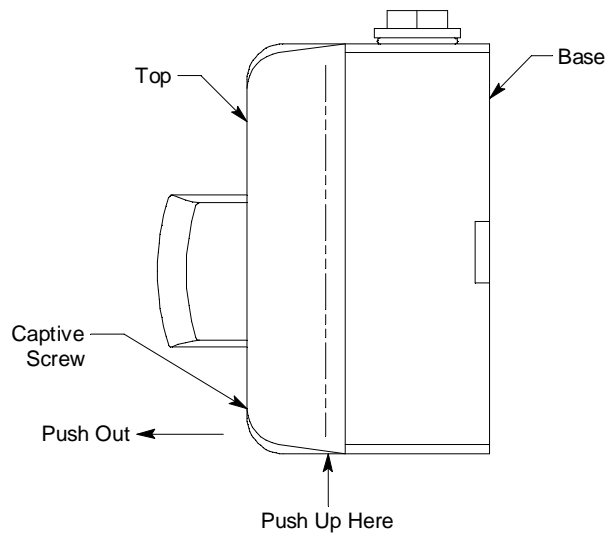

Figure 13. Top Case Removal

5. Turn the cover over and locate the Audio Select switch at the top of the cover as shown in the figure below.

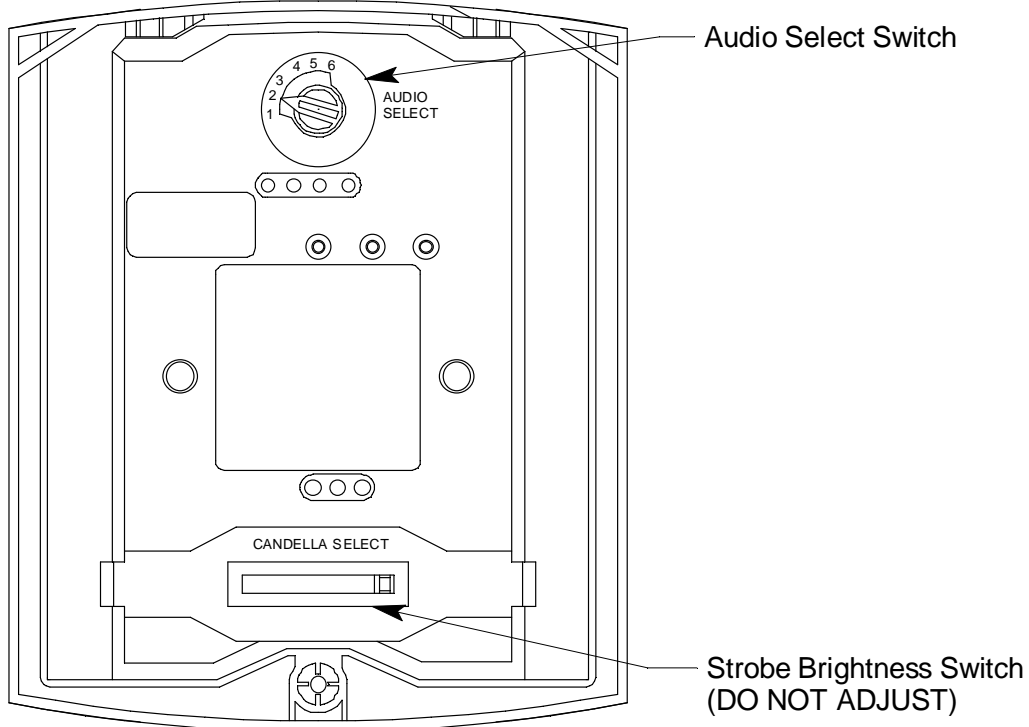

Figure 14. Strobe/Horn Cover

6. The Audio Select switch can be set at any number between 1 and 6. Numbers 1-3 all produce an intermittent buzzing sound with 1 being the loudest and 3 being the quietest. Numbers 4-6 all produce a steady buzzing sound with 4 being the loudest and 6 being the quietest. The factory setting is 2.
7. Turn the Audio Select switch so that the selection arrow is pointing to the desired number.
8. Place the cover over the base and push in and down in order to reinstall the cover. Make sure that the cover is sealed to the base by the gasket.
9. Screw the captive screw at the bottom front of the strobe/horn back in.

Replacing Components of the Rig Monitor

This section describes how to replace the fuses, the plug-in H₂S sensor, and the entire H₂S detector.

Replacing the Fuses

1. Open the housing door of the Rig Monitor, then place the power switch in the OFF position.
2. Disconnect the battery clamps from the + and - terminals of the 12 VDC battery.
3. Locate the vertical fuse holders on either side of the power switch. The DC fuses are labelled F2 and F3 and are on the right of the power switch.
4. Use a flat-blade screwdriver to rotate the applicable fuse holder 1/4 turn counterclockwise. The fuse holder releases from the socket.
5. Remove the fuse holder from the socket, then remove the fuse from the fuse holder.

CAUTION: *Verify that the replacement fuse is the same type and rating as the fuse you are replacing.*

6. Install the appropriate replacement fuse in the fuse holder, then place the fuse holder in the socket.
7. Push the fuse holder into the socket, then turn the holder 1/4 turn clockwise to secure it in the socket.
8. Connect the battery clamps to the + and - terminals of the 12 VDC battery.
9. Place the Rig Monitor's power switch in the ON position, then verify that the PILOT light is on.
10. Close and secure the housing door.

Replacing the LEL Detector

1. Open the housing door of the Rig Monitor, then place the power switch in the OFF position.
2. Disconnect the battery clamps from the + and - terminals of the 12 VDC battery.
3. Remove the LEL detector junction box cover.

4. Disconnect the detector leads from the terminal block in the junction box. Note the position of the color-coded leads as you remove them.
5. Unscrew the calibration cup from the detector.
6. Unscrew the detector from the junction box hub.
7. Guide the detector leads of the replacement detector through the junction box hub then screw the mounting threads of the detector into the hub.
8. Connect the detector leads to the terminal block the same way the old detector was wired. See Figure 9 to verify the connections are correct.
9. Screw the calibration cup onto the new detector.
10. Reinstall the junction box cover.
11. Connect the battery clamps to the + and - terminals of the 12 VDC battery.
12. Place the Rig Monitor's power switch in the ON position, then verify that the PILOT light is on.

CAUTION: *Allow the replacement detector to warm up for 5 minutes before you continue with the next step.*

13. Calibrate the replacement detector as described in the Calibration section of this manual.

Replacing the Plug-In H₂S Sensor

1. Open the housing door of the Rig Monitor, then place the power switch in the OFF position.
2. Disconnect the battery clamps from the + and - terminals of the 12 VDC battery.
3. Unscrew the calibration cup/splash guard from the detector.
4. Unscrew the detector housing cap from the housing body. Make sure not to lose the cap gasket. See Figure 4 for an illustration of the H₂S detector.
5. Unplug and remove the sensor.
6. Carefully match the replacement sensor's male pins with the 4-socket pattern in the top section and plug it in.
7. Make sure the cap gasket is in place and screw the detector housing cap back onto the housing body.
8. Screw the calibration cup/splash guard back onto the detector housing cap.

9. Connect the battery clamps to the + and - terminals of the 12 VDC battery.
10. Place the Rig Monitor's power switch in the ON position, then verify that the PILOT light is on.

CAUTION: *Allow the replacement sensor to warm up for 15 minutes before you continue with the next step.*

11. Calibrate the detector as described in "Calibration Program" on page 33.

Replacing the H₂S Detector

NOTE: In most cases, it is only necessary to replace the H₂S sensor.

1. Open the housing door of the Rig Monitor, then place the power switch in the OFF position.
2. Disconnect the battery clamps from the + and - terminals of the 12 VDC battery.
3. Remove the H₂S detector junction box cover.
4. Disconnect the detector leads from the terminal block in the junction box. Note the position of the color-coded leads as you remove them.
5. Unscrew the calibration cup/splash guard from the detector housing cap.
6. Unscrew the detector from the junction box hub.
7. Guide the detector leads of the replacement detector through the junction box hub then screw the mounting threads of the detector into the hub.
8. Connect the detector leads to the terminal block the same way the old detector was wired. See Figure 9 to verify the connections are correct.
9. Screw the calibration cup/splash guard onto the new detector's housing cap.
10. Reinstall the junction box cover.
11. Connect the battery clamps to the + and - terminals of the 12 VDC battery.
12. Place the Rig Monitor's power switch in the ON position, then verify that the PILOT light is on.

CAUTION: Allow the replacement detector to warm up for 5 minutes before you continue with the next step.

13. Calibrate the replacement detector as described in the Calibration section of this manual.

Preventive Maintenance

This section describes a preventive maintenance schedule to ensure the optimum performance of the LEL and H₂S detectors. It includes daily, monthly, and quarterly procedures.

Daily

Verify a display reading of 0 %LEL and 0 PPM H₂S at the controller. Investigate significant changes in the display reading.

Monthly

This procedure describes a test to verify that the LEL and H₂S detectors respond properly to their target gas. It describes a test using a fixed flow regulator with an on/off knob. RKI Instruments, Inc. recommends using a 0.5 LPM (liters per minute) fixed flow regulator.

NOTE: Performing a response test on the LEL and H₂S detectors may cause alarms. Be sure to disable external alarms or put the Rig Monitor into its calibration program before performing this test.

Preparing for the response test

1. While in normal operation, press and hold the UP/YES button for 5 seconds and press the UP/YES button again when asked if you would like to enter Calibration Mode.
2. Verify that the Rig Monitor display reading is 0 %LEL and 0 ppm H₂S.
3. If the display reading is not 0 %LEL or 0 ppm H₂S, set the zero reading of the detector as described in the Start Up section of this manual, then continue this procedure.
4. Screw the regulator into the LEL calibration cylinder.

NOTE: Ensure that you are using an appropriate calibration cylinder for the channel you are testing.

5. Use the calibration kit sample tubing to connect the regulator to the calibration cup/splash guard of the LEL detector.

Performing the response test

1. Turn the regulator's on/off knob counterclockwise to open the regulator. Gas will begin to flow.
2. Allow the gas to flow for one minute, then verify that the reading is within $\pm 20\%$ of the cylinder gas concentration.

NOTE: If the reading is not within $\pm 20\%$ of the correct response reading, calibrate the detector as described in the Calibration section of this manual.

3. Turn the regulator's on/off knob clockwise to close the regulator.
4. Detach the sample tubing from the calibration cup.
5. Unscrew the regulator from the calibration cylinder.
6. Screw the regulator into the H₂S calibration cylinder.
7. Attach the sample tubing to the H₂S detector calibration cup.
8. Turn the regulator's on/off knob counterclockwise to open the regulator. Gas will begin to flow.
9. Allow the gas to flow for two minutes, then verify that the reading is within $\pm 20\%$ of the cylinder gas concentration.

NOTE: If the reading is not within $\pm 20\%$ of the correct response reading, calibrate the detector as described in the Calibration section of this manual.

10. Turn the regulator's on/off knob clockwise to close the regulator.
11. Detach the sample tubing from the calibration cup.
12. Unscrew the regulator from the calibration cylinder.
13. When the Rig Monitor display reading falls below the alarm setpoints, return it to normal operation or enable alarms.
14. Store the components of the calibration kit in a safe place.

Quarterly

Calibrate the LEL and H₂S detectors as described in the Calibration section of this manual.

Troubleshooting

The troubleshooting guide describes symptoms, probable causes, and recommended action for problems you may encounter with the Rig Monitor.

Table 9: Troubleshooting the Beacon 200 Rig Monitor

Condition	Symptom(s)	Probable Causes	Recommended Action
No Power	<ul style="list-style-type: none"> The PILOT light is off. The display screens are blank. 	<ul style="list-style-type: none"> The power wiring is disconnected or misconnected. One or both DC fuses are blown. The display cable is disconnected or misconnected. The battery is dead or at a very low voltage. 	<ol style="list-style-type: none"> Verify that the wiring to the battery is correct and secure. At the Beacon 200, verify that the wiring to the DC terminals is correct and secure. Check the continuity of the DC fuses. Verify that the display cable is connected. The display (ribbon) cable plugs into connectors on the top edge of the display board (labeled J1) and on the top edge of the main circuit board (also labelled J1). If the power difficulties continue, contact RKI for further instruction.
Frequent or Suspect Alarms	<ul style="list-style-type: none"> The Beacon 200 alerts you to frequent or suspect alarms. The detector head's fresh air readings remain on zero. 	<ul style="list-style-type: none"> The Beacon 200 is experiencing false readings due to RFI or EMI. The detector head wiring is disconnected, misconnected, or intermittent. 	<ol style="list-style-type: none"> Verify that the detector head wiring is properly shielded. Verify that the detector head wiring is correct and secure. Verify that power and detector head wiring is routed through separate conduit hubs on the bottom of the Beacon 200 housing. Increase the alarm on delay setting in the Channel Control & Setup Program. If the frequent or suspect alarm difficulties continue, contact RKI for further instruction.
Flickering Display	<ul style="list-style-type: none"> The display readings flicker often. 	<ul style="list-style-type: none"> The Beacon 200 is experiencing false readings due to RFI or EMI. The noise filter setting is too low. The zero suppression setting is too low. The display screen is malfunctioning. 	<ol style="list-style-type: none"> Verify that the detector head wiring is properly shielded. Verify that the detector head wiring is correct and secure. Verify that power and detector head wiring is routed through separate conduit hubs on the bottom of the Beacon 200 housing. Increase the noise filter setting in the Channel Control & Setup Program. Increase the zero suppression setting in the Channel Control & Setup Program. If the display difficulties continue, contact RKI for further instruction.
Buzzer Not Working	<ul style="list-style-type: none"> The buzzer does not sound an audible alarm during alarm conditions. The buzzer sounds weak or broken. 	<ul style="list-style-type: none"> The buzzer is disconnected or misconnected. The buzzer is malfunctioning. 	<ol style="list-style-type: none"> Verify that the wiring to the BUZ- and BUZ+ terminals of the controller terminal strip is correct and secure. If the buzzer difficulties continue, contact RKI for further instruction.

Table 9: Troubleshooting the Beacon 200 Rig Monitor (Continued)

Condition	Symptom(s)	Probable Causes	Recommended Action
Reset Switch Not Working	<ul style="list-style-type: none"> • The buzzer does not silence when you press the reset switch. • The applicable alarm circuit does not reset when you press the reset switch after an alarm condition passes. 	<ul style="list-style-type: none"> • The reset switch is disconnected or misconnected. • The reset switch is malfunctioning. 	<ol style="list-style-type: none"> 1. Verify that the wiring to the RESET (2) terminals of the controller terminal strip is correct and secure. 2. If the reset switch difficulties continue, contact RKI for further instruction.
Strobe/Horn Not Working	<ul style="list-style-type: none"> • The strobe/horn does not activate when an alarm 1 condition occurs. 	<ul style="list-style-type: none"> • The strobe/horn is malfunctioning. • The strobe/horn wiring is disconnected or misconnected. 	<ol style="list-style-type: none"> 1. Verify that the strobe/horn is wired properly to the alarm terminal strip. 2. If the strobe/horn difficulties continue, contact RKI for further instruction.
Fail Condition	<ul style="list-style-type: none"> • Rig Monitor indicates a fail condition. • Controller indicates a fail condition. 	<ul style="list-style-type: none"> • The detector wiring to the main PCB is disconnected or misconnected. • The plug-in H₂S sensor is not properly plugged into the sockets in the detector housing body. • The detector fresh air signal is low enough to cause a fail condition. • The detector is malfunctioning. • The main or display PCB is malfunctioning. 	<ol style="list-style-type: none"> 1. Verify that the detector wiring is correct and secure. 2. Confirm that the plug-in H₂S sensor is installed properly. 3. Calibrate the Rig Monitor. 4. If the fail condition continues, replace the detector. 5. If the fail condition continues, contact RKI for further instruction.
Slow or No Response/ Difficult or Unable to Calibrate	<ul style="list-style-type: none"> • Rig Monitor responds slowly or does not respond to response test. • Unable to successfully set the fresh air or span reading during calibration. • Rig Monitor requires frequent calibration. <p><i>Note: Under “normal” circumstances, the detector requires calibration once every 3 months. Some applications may require a more frequent calibration schedule.</i></p>	<ul style="list-style-type: none"> • The calibration cylinder is low, out-dated, or defective. • The flame arrestor in the H₂S detector housing cap or the LEL flame arrestor is wet or clogged with dirt or other particulates. • The detector is malfunctioning. • The main PCB is malfunctioning. 	<ol style="list-style-type: none"> 1. Verify that the calibration cylinder contains an adequate supply of a fresh test sample. 2. Verify that the calibration gas concentration is appropriate for the detector. Zero emission air (0 %LEL and 0 ppm H₂S) is normally used for a zero adjustment if the environment is suspect and 50% LEL and 25 PPM H₂S in nitrogen is normally used for a response adjustment. 3. Check the H₂S detector housing cap and the LEL detector to determine if the flame arrestor is wet or dirty. Clean if necessary. 4. If the calibration/response difficulties continue, replace the detector. 5. If the calibration/response difficulties continue, contact RKI for further instruction.

Parts List

Table 10 lists the part numbers and descriptions for replacement parts and accessories offered for the Beacon 200 Rig Monitor.

Table 10: Parts List, Beacon 200 Rig Monitor

Part No.	Description
06-1248RK-03	Sample tubing for calibration, 3 foot length
07-0033RK	Detector housing cap gasket for H ₂ S detector
18-0061RK	Cable bushing
18-0107RK	Conduit Hub (3/4 in.)
18-0400RK-01	Junction box with rubber spacers
43-0440RK	Reset Switch
43-4155RK	Fuse, 1/4" x 1 1/4", fast acting, 3A, 250 V
51-0096RK	Strobe/horn, 10-33 VDC, NEMA 4X
52-1016RK	Buzzer
61-0140RK-01	Replacement LEL detector
65-2423RK-05	H ₂ S detector (with plug-in sensor)
65-2427RK-05	H ₂ S sensor with j-box (does not include cable and cable bushing)
71-0243RK	Combustible Gas and Hydrogen Sulfide Beacon 200 Rig Monitor Operator's Manual (this document)
81-0012RK-01	Calibration cylinder, 50% LEL methane in air, 34 liter steel
81-0012RK-03	Calibration cylinder, 50% LEL methane in air, 103 liter steel
81-0076RK	Zero air calibration cylinder, 17 liter steel
81-0076RK-01	Zero air calibration cylinder, 34 liter steel
81-0076RK-03	Zero air calibration cylinder, 103 liter steel
81-0151RK-02	Calibration cylinder, 25 PPM H ₂ S in nitrogen, 58 liter aluminum
81-0151RK-04	Calibration cylinder, 25 PPM H ₂ S in nitrogen, 34 liter aluminum
81-1050RK	Regulator with gauge and knob, 0.5 LPM, for 17 liter and 34 liter steel calibration cylinders
81-1051RK	Regulator with gauge and knob, 0.5 LPM , for 34AL/58/103 liter calibration cylinders
81-1112RK-01	Calibration cup with diffuser holes for LEL detector
81-1116RK	Calibration cup/splash guard for H ₂ S detector
ES-1537-H2S	H ₂ S replacement sensor